

**DRAFT**

# **ENVIRONMENTAL ANALYSIS REPORT**

**BASIS FOR FACADE SOLAR PROTECTION  
JULY 2019**

**Proposed Development on Lot 1027,  
Seksyen 57, Jalan Changkat Raja Chulan  
for GBD Development Sdn. Bhd.**

# Contents

G B D T O W E R

**01 EXECUTIVE SUMMARY AND RECOMMENDATIONS**

**02 PROJECT EVALUATION**

**03 METHODOLOGY**

**04 LOCATION AND WEATHER**

**05 SOLAR ANALYSIS**

**06 VENTILATION ANALYSIS**

**07 THERMAL ANALYSIS**

**08 PROPOSALS AND RECOMMENDATIONS**

**09 BIBLIOGRAPHY**

# 01 Executive Summary and Recommendations

A series of simulations were carried out taking into account the GBD tower solar radiation, wind, thermal, and daylight aspects of the design.

## Solar Radiation

**i** The vertical solar protection of the NE, NW, and SW facades is proposed.

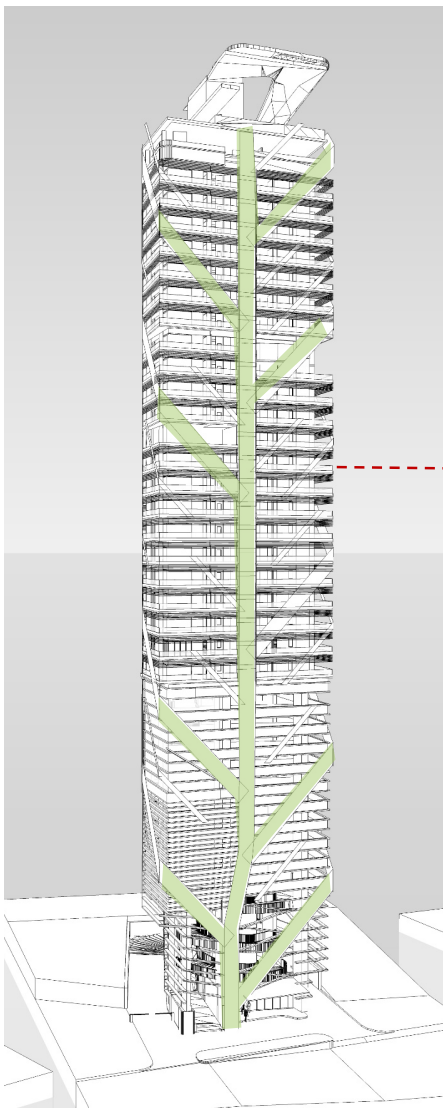

The Solar penetration in the east and west orientation is very high. The solar rays fall on facade of these orientations almost horizontally in the morning and in the evenings. Therefore, in order to avoid Direct solar radiation and to generate thermal physical comfort inside the building it is necessary to shade these facade.

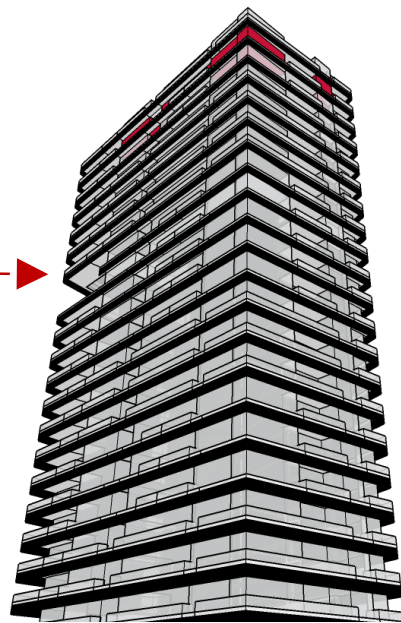

Horizontal louvres elements made of aluminium are preferred elevation to be used as sun shades.

# ii

The best orientation for the building and spaces, as a general rule, is Southward and Northward so it is not necessary to provide a vertical sun shading elements on the south facade.

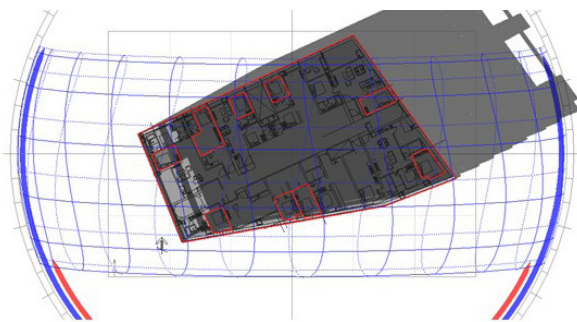

South Facade Solar Penetration Figure 5.3.c (Page 21)  
Typical floor plan and solar penetration on 21  
December at 17.00 pm

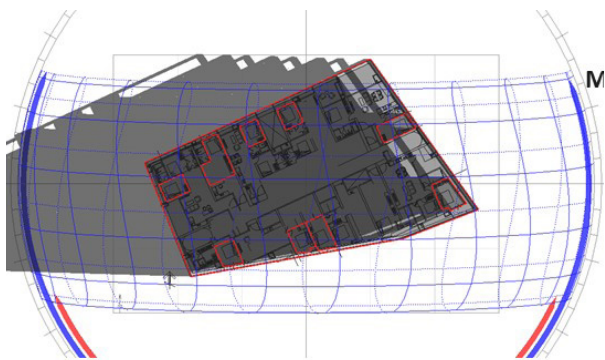

South Facade Solar Penetration Figure 5.4d (Page 22)  
Typical floor plan Solar penetration on 21 March and  
September at 9.00 am

## Solar Radiation

The effect of the orientation is one of the most important design variables to control the indoor comfort of the building. In the current scheme, the longest facade of the building is facing North- South direction and each facade has large balconies that will protect the building from direct exposure to the sun. The Solar irradiation received on the south and north facades have lower values compared to the other facade orientations ,Northwest facade receives the maximum radiation.

In the South Facade the Sun light's penetration is is controllable by the large balconies and building opposite it.

# Solar Radiation



## Provide Vertical shading

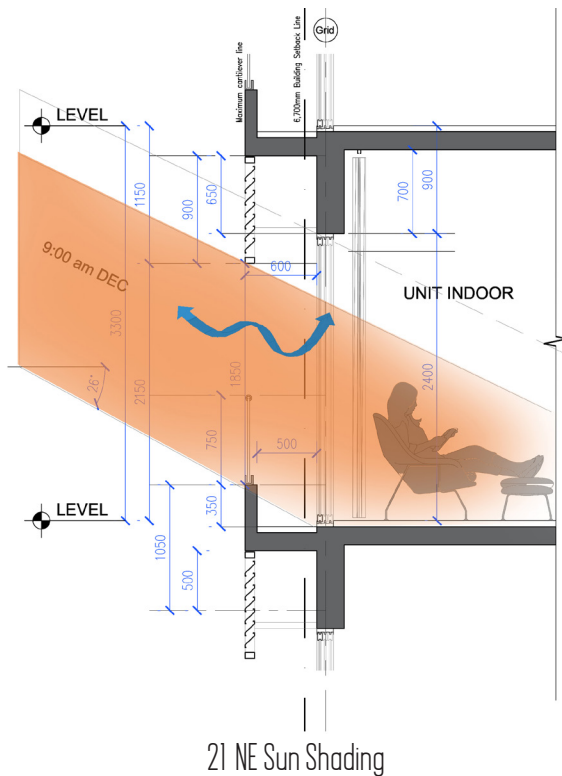

To have a comfortable illumination (diffused) and to avoid glare, short-wave and long-wave radiation from entering the building, vertical louvres are preferred. Comparing the graphics of Ecotect Software Figure 7.4, (Pg 45) the one that has a considerable solar protection and has acceptable illumination.

After comparing the analysis results with the building standard, it has been noticed that the daylight factor inside the room is higher than the desired values. Therefore in order to control the amount of light entering the room, horizontal louvres with 55CM depth are preferred, that will further help in protecting from the glare and direct solar radiation.



# iv

Use of high perennial vegetation in the main entrance facade ( drop off)



To shade open spaces and entrance. In addition to humidifying the prevailing winds.

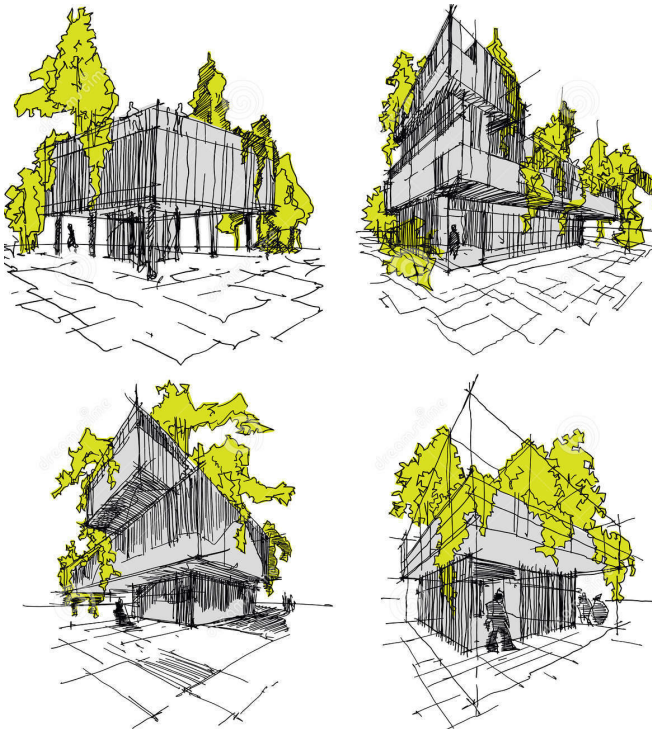

# Solar Radiation



# v

Use of vegetation on the facade of building (Sw,NE and NW) like Green wall ,balconies, pergolas to generate solar protection

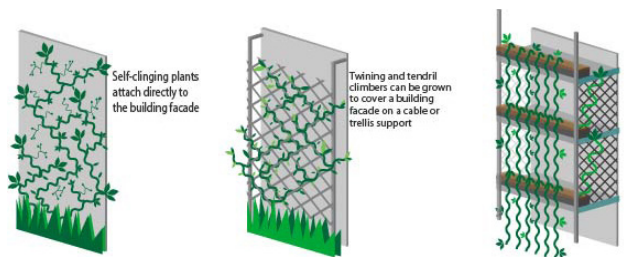

To have lower temperature and encourage ingress of natural ventilation inside the buildings and to reduce heat island .

# Material



## vi

**Use light colours, flooring tiles and rough surfaces on façades and on roofs.**

To regulate the indoor temperature and avoid overheating. Also to have a good reflection of light. Internal ( wall colour reflectance 80% and flooring tiles 60%.)

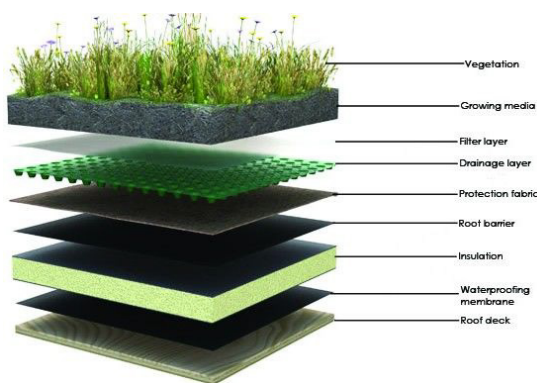

## vii

**Use Insulating materials , light materials and resistant to humidity with high thermal inertia**

To regulate the indoor temperature

## viii

**Use of glass with low thermal conductivity coefficients is recommended (low U value:1.6 w/sq.m),(low SC (shading coefficient) :0.2 , high VLT:50% ,Low Emissivity and to provide sun shading over window if simple or laminated glass is used also to reduce the amount of glass on the façades**

As the glass will generate a high heat conductivity inside the environments causing discomfort. In the graphic Figure 8.1 (Pg 43) that the room is out of comfort currently without sun shading the indoor temperatures inside the building were evaluated and the gain is approximately 2 degrees more compared to the outside temperature according to ecotect software temperature and the gain in the hottest month is 3956.2 W/h (notably high) in graphic table 8.2 (Pg 43) as it is using simple glass is necessary in addition to not generate so high W/h and protect the windows from radiation (UV and infrared rays).

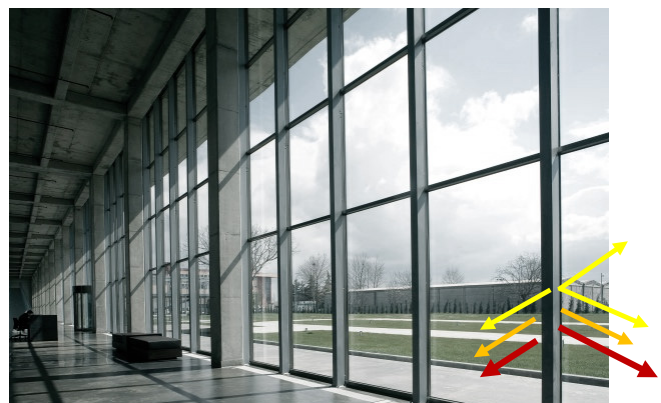

# ix

Use of drainage systems in roof floors and gutters. Use shutters for storm damage protection and operable perforated shutters.

As waterproof and resistant to rain and moisture. Non-slip, porous and textured floors rough.



# Material

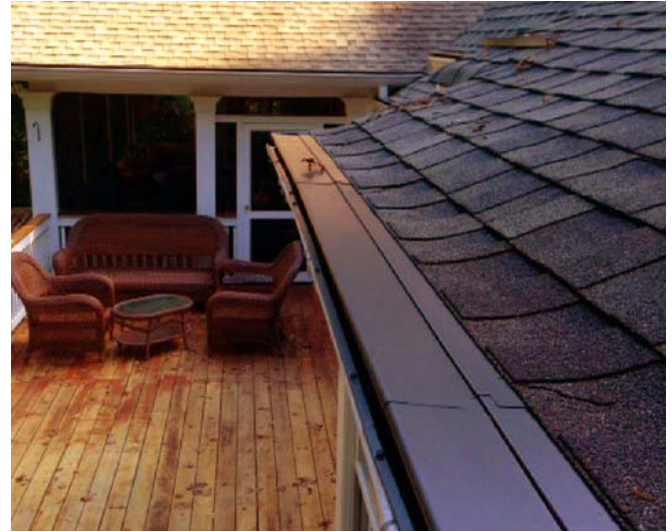

# xi

Use full operable windows. Ventilation opening ( check prevailing winds and place on windward upwind and downwind façade). Average opening of the

It will ensure better ventilation compared to other types of windows because there is more air volume.

# X

Open plan design concept and use light weight forms

To reduce indoor temperature and to have ventilation

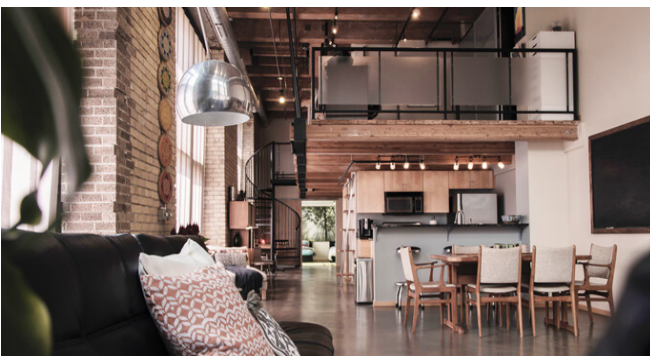



# Ventilation

## xii

Use convective ,cross and external open access corridors and venturi effect ventilation average opening of the windows, average opening of the windows, 30-40% of the height of people .

Cross-ventilation is needed to provide fresh air, to cool the body and to cool the building according to the table (7.1) for adequate ventilation to take advantage of the cold and hot air pressure difference , use of venturi effect ventilation in the day and night due to the high temperatures that are above the 30c ° on average throughout the summer high ceilings, with ventilated spaces promoting cooling because that allows to regulate the indoor temperature.

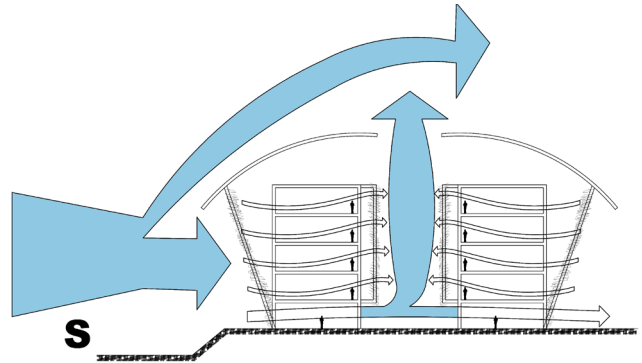

## xiii

**Use double volume and high interior ( 3.00 to 3.50 meter )**

Allows the stratification of the hot air and provides good ventilation .

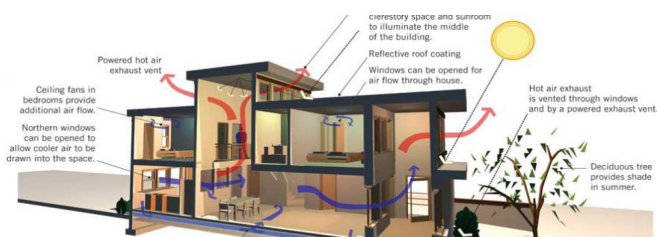

## 02 Project Evaluation

The purpose of this report is to study and analyse the solar and thermal behaviour of the residential tower (Grand Bond Tower) in Kuala Lumpur, Malaysia. This city has a latitude of  $3^{\circ} 09' 28''$  N, it belongs to the southern tropics, a west longitude of  $101^{\circ} 42' 42''$  E, it presents a climate with high temperature value throughout the year and a high value of humidity. Being located in the tropics, the sun's path has a vertical tendency, for this reason, heating is more on horizontal surfaces and less on vertical surfaces. The way in which the architectural element will have to be adapted to the climate variables of Kuala Lumpur with the purpose of generating comfort inside the building's environments will be studied, therefore the solar incidence, the daylight, the ventilation and the thermal analysis are going to be analysed. Also the material of the walls, glass and of different architectural elements that the building is made of. The thermal behaviour and its relation with the climate of Kuala Lumpur will be analysed, generating design strategies and recommendation necessary to achieve the comfort. the solar incidence within the building, as well as direct radiation, the w/h gained from the spaces studied, ventilation and the importance of using solar protection on the facades.

## 03 Methodology

The methodology for the study is analytical. The following procedures will be carried out: data collection of the architectural object and the place of study, processing of them with the help of Ecotect software, analysis of the processed data supported by the concepts related to behaviour of the architectural elements and evaluation of the insertion of the building to the natural environment considering the climate as one of its most important elements, finally verifying the degree of efficiency of said insertion.

# 04 Location and Weather

## 4.1 Location of the Project

GBD Project is located in Kuala Lumpur. This city is located within the equatorial area as it is located  $3^{\circ} 09' 28''$  N, it belongs to the southern Tropics, a length of  $101^{\circ} 42' 42''$  E. Equator is the parallel that maintains its position more constant with respect to the sun.

The rays of the sun affect very vertically and fall perpendicularly twice a year, in the Equinox of spring and autumn causing that the regions that are within this zone receive a considerable load of sunstroke, but this one is not so marked, due to the high humidity contained in its atmospheric mass. This zone yields energy continuously by means of ocean currents and displacement of the atmospheric mass.

### Equatorial zone architecture that limits the trees

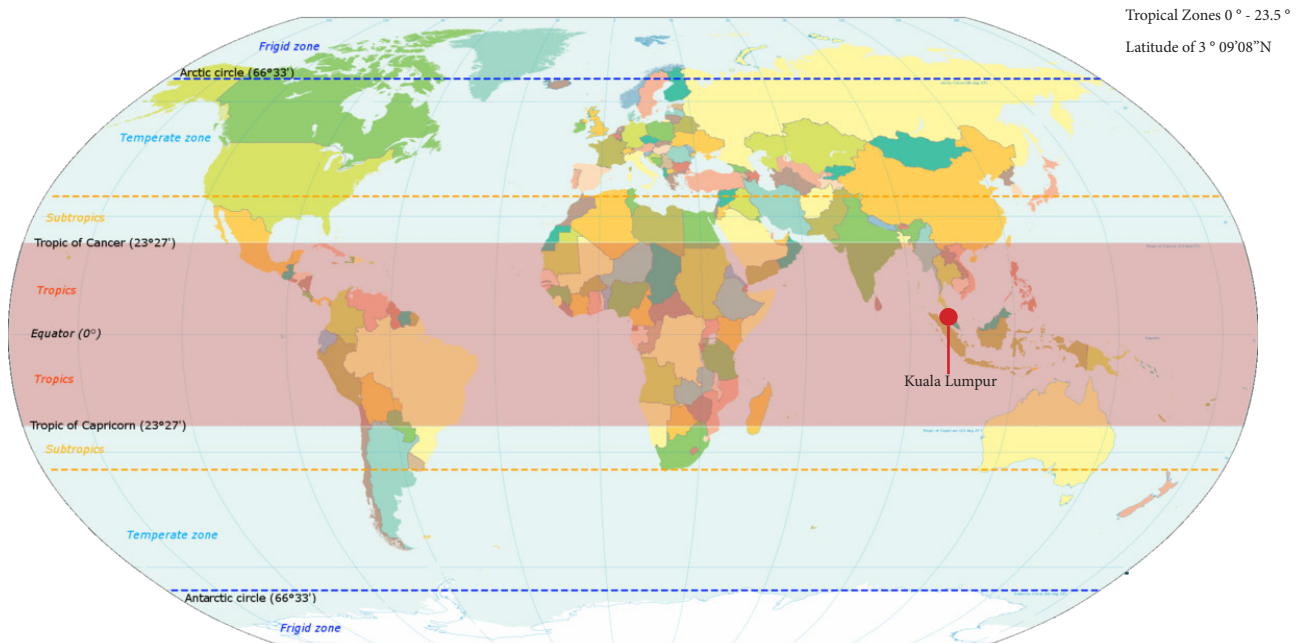

Source Fig 1: Tesina Fuente tesina the game of geometries under the sun.

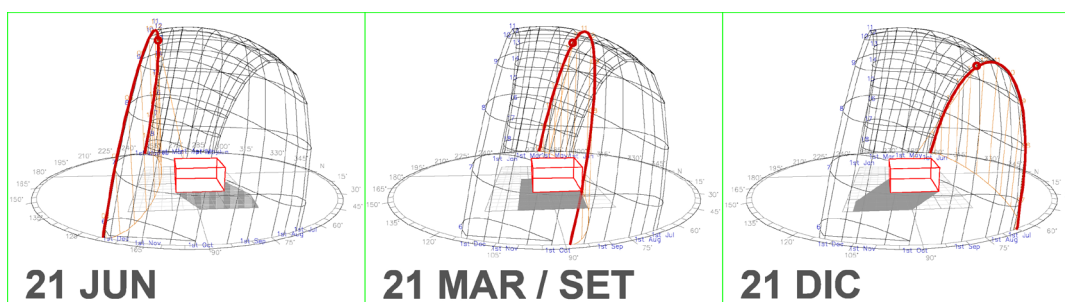

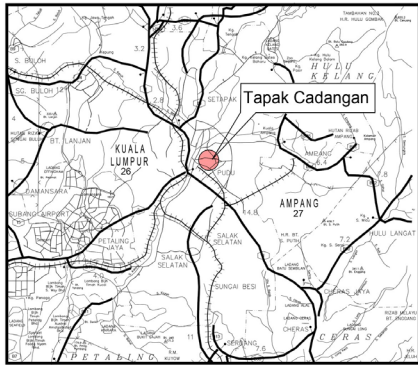

KEY PLAN

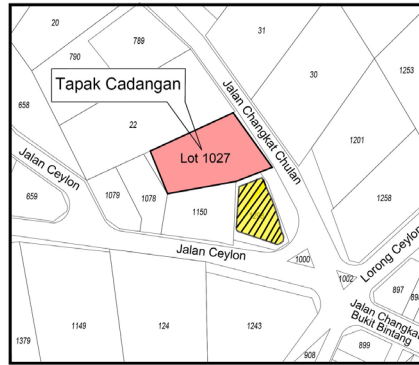

LOCATION PLAN



Figure 2 and 3: shows the Key and Location map of the building and perspective view

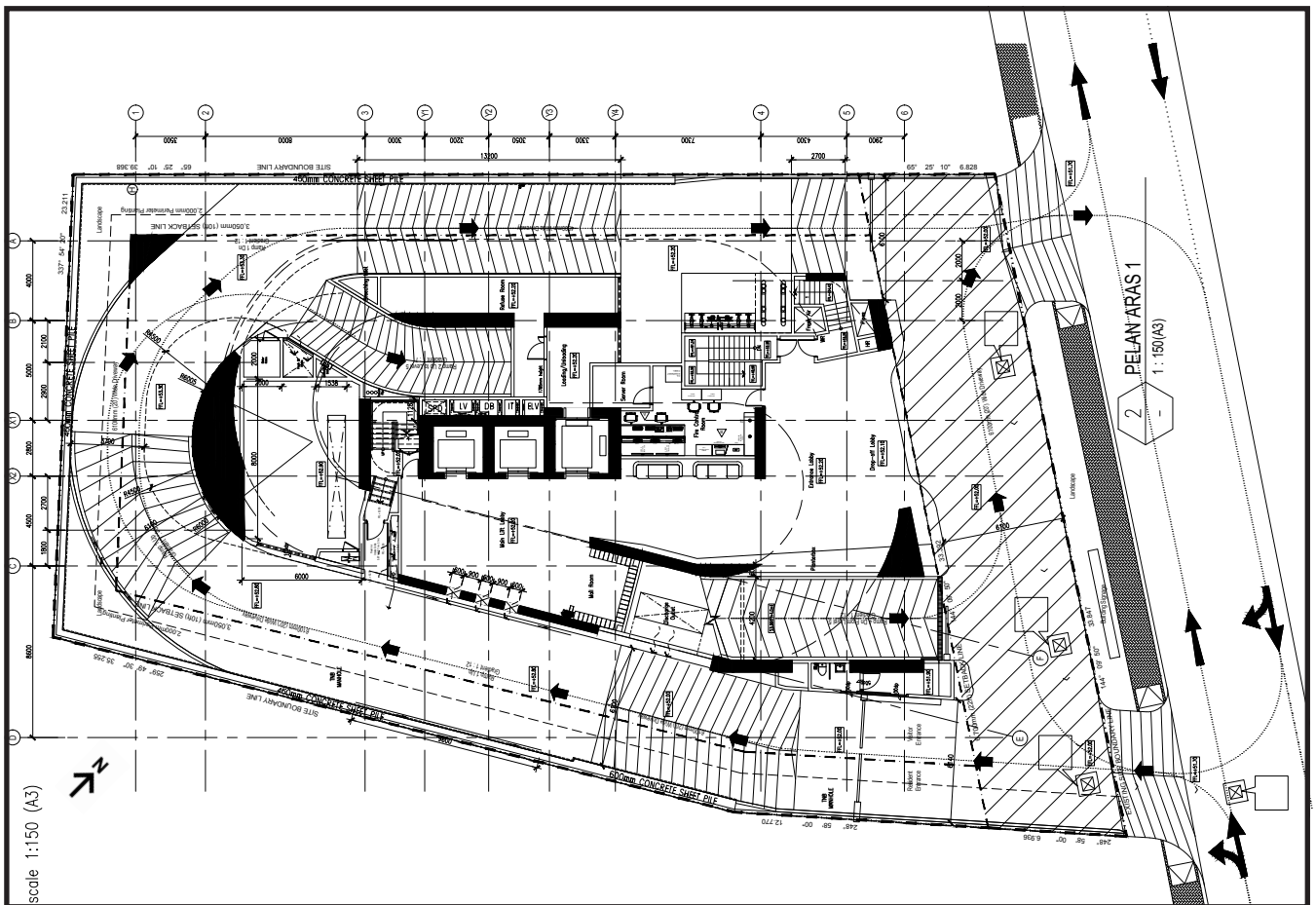

Figure 4: shows the level 2 of the building ( entrance )

# 4.2 Weather

## TEMPERATURE

		UNIT OF MEASUREMENT	JANUARY	FEB.	MARCH.	APRIL.	MAY.	JUNE.	JULY.	AUGUST.	SEPT.	OCT.	NOV.	DEC.
TEMPERATURE	MAXIMUM MEDIA	C°	31.4	32.4	32.8	32.6	32.4	32.3	31.9	31.9	31.6	31.5	31.2	31.2
	MEDIA		26.5	27.2	27.5	27.7	27.7	27.4	27.0	27.4	26.8	26.9	26.7	26.5
	MINIMUM MEDIA		21.7	22.0	22.2	22.8	23.0	22.6	22.1	22.9	22.1	22.3	22.3	21.9

The maximum temperature occurs in the months of March, April and May.  
 The minimum temperature is in the months of December, January and February.  
 We take the average temperature of the 3 hottest months to take out the comfort axis

LOCATION: LATITUDE: 3 ° 09'28 "N LENGTH: 101 ° 42'42" E

- 27.5
- 27.7
- 27.7

27.63 ← AVERAGE → Closer to 26.7 °C

$27.63 + 0.66$  (CLO) = 28.29  
 $27.63 - 0.66$  (CLO) = 26.97

Difference throughout the year  
 minimum 23.0 - 21.7 = 1.3  
 maximum 32.8 - 31.2 = 1.6  
 temperature stable

Difference throughout the year  
 January 31.4 - 21.7 = 9.7  
 July 31.9 - 22.1 = 9.8  
 November 31.2 - 22.3 = 8.9

The comfort zone goes from 21.00 ° C to 26.7 ° C - It is not within Comfort Kuala Lumpur nor the comfort axis being 27.63 degrees neither is this within comfort with the clo

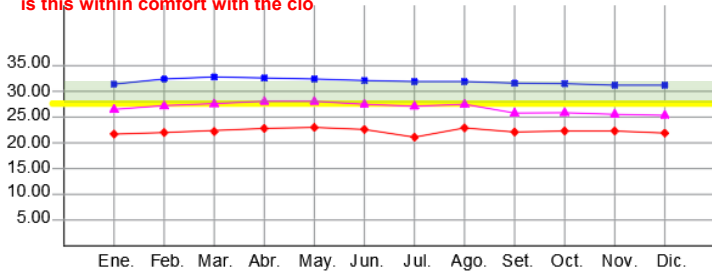

CLO	
UNDERWEAR	0.04
SLEEVELESS SHIRT	0.06
SHORT	0.06
SNEAKERS	0.09
	0.25

1 clo → 7.3 °C  
 0.25 → 1.38 °C

+0.66 °C  
 1.32  
 -0.66 °C

NEITHER IS THIS WITHIN COMFORT WITH THE CLO

Relationship with comfort

The temperature is always above the comfort.

Temperature

## HUMIDITY

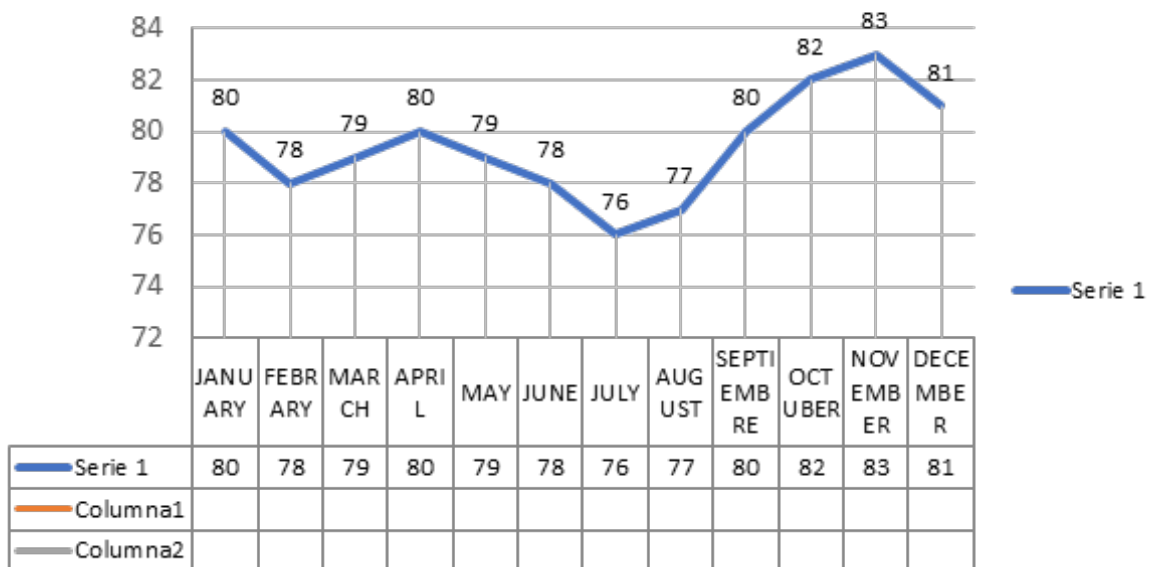

Humidity

It is visible in the graph that the maximum temperature is throughout the year above the comfort. The minimum to change is within the range of comfort (21 to 26.7 degrees). The average in the same way is generally out of comfort. Relative humidity is above comfort reaching up to 83% of Hour in the month of November. These data shows that Kuala Lumpur has a warm humid climate.

## Ombrothermic Graphic

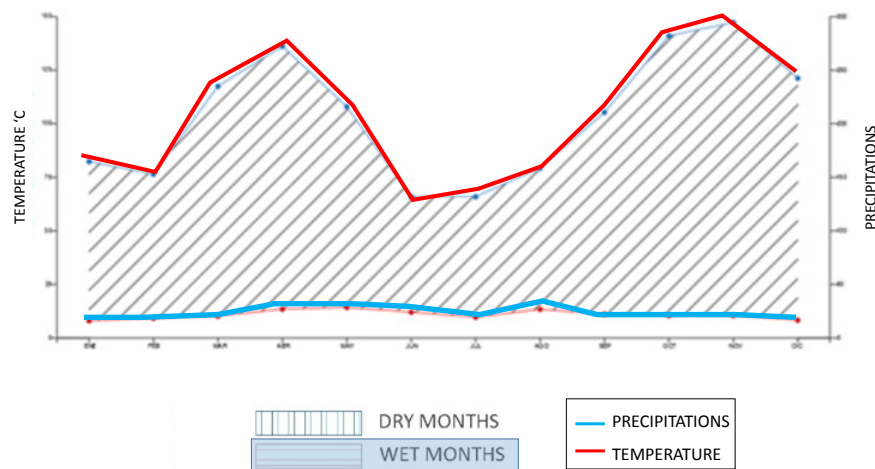

Kuala Lumpur has rainfalls throughout the year. According to the chart it is a humid climate because the precipitations are above the temperature line. The months with higher precipitations are from February to May and from October to December being the month with highest precipitation is November with 296 m/m, however the whole year has precipitation with very high values.

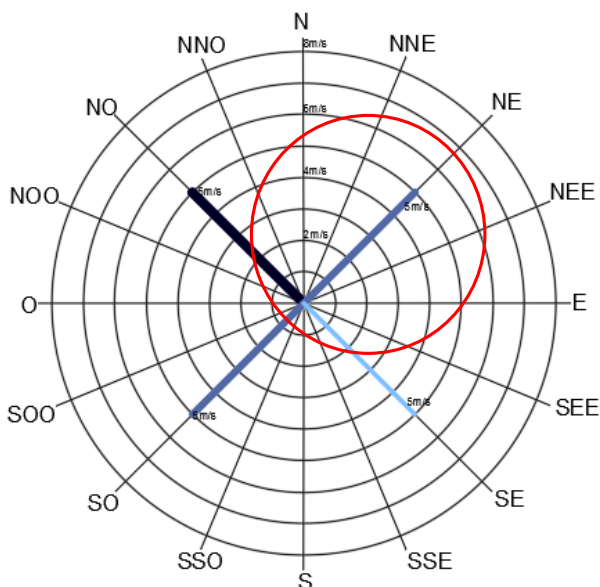

## Wind Rose Diagram

The average velocity of winds is 5 m/s with the direction of more frequent winds of NW (5 months) and NE (3 months) according to the graph.

# Bioclimatic of Gioveni

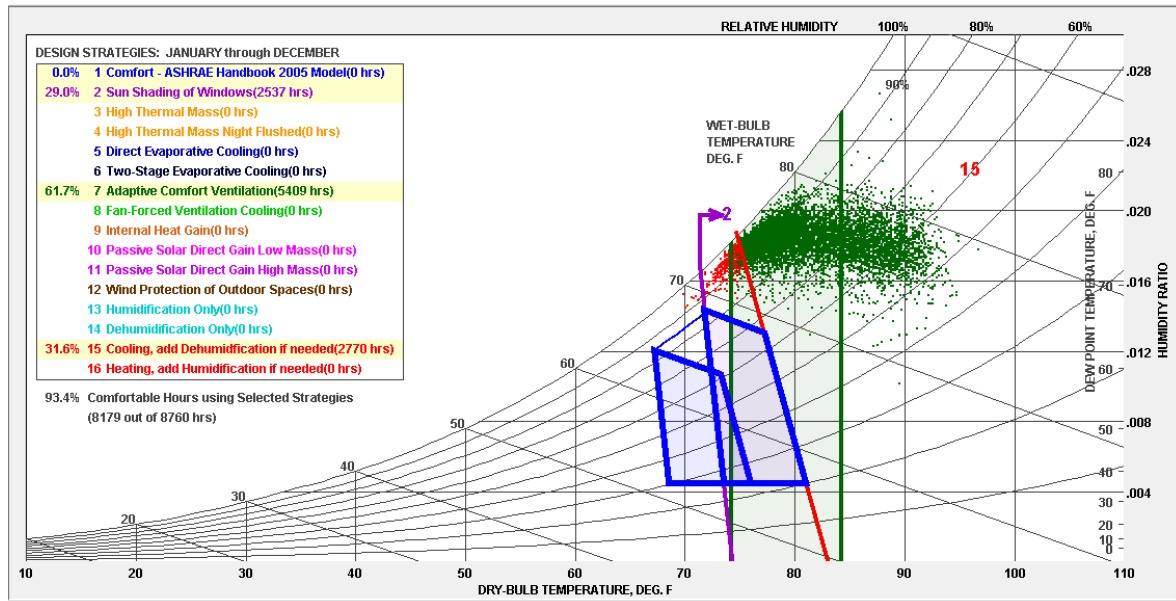

Giovanni Structure Bio climatic Chart shows that the temperatures and relative humidity are very high and the indoor area are out of comfort. Only in a few months are inside the comfort area (but almost at the edge of the comfort zone).

As a strategy it will be necessary to constantly ventilate all indoor areas. We can conclude that temperatures are above comfort all year round and the environment is loaded with a high (%) relative humidity. Therefore, the vapour content of air water has a greater effect of absorption of direct radiation, thus presenting a greater amount of diffuse radiation, this being the one that most affects these regions.

In this zone, the seasons are not differentiated, expect by the rain regime and the amount of relative humidity. The radiation is usually uniform throughout the year, as well as the duration of the days. Precipitation falls in large quantities with a great regularity, almost daily. For this reason, the roof is the main element of architecture. In this locality it is important to protect from the sun and the constant precipitation. For this reason, the roofs are wide, inclined and with eaves, to protect interior inside and the vertical enclosures of the radiation, both direct and diffuse, and of the the heavy rain. The walls are irrelevant, in some cases they don't even exist, the limits of the house are defined by the shadow that the cover projects. The traditional construction tends to be light, as well as its materials, which must be dried quickly, also lacking thermal inertia due to the low temperature variability. The main concern is ventilation, because it allows the evaporation of moisture, achieved through maximum exposure to breezes.

# Climate Conclusions

- Kuala Lumpur is located in a tropical zone according to the Koppen GEIGER climate classification.
- It has a of the type, warm climate with relative humidity of an average of 67% per year and with heavy and constant rains from June to September.
- High Temperature with an average of 34c° from January to April.
- During summer months the temperature oscillation is very wide of 7c° on the average. At night the temperature drops. In Winter, the temperature oscillation is 11 c' on average.
- It presents Considerable precipitations in the months of summer in the months of winter.
- The difference between summer and winter temperature is minimum for the whole year . Highest value of the temperature to control during the day
- Predominant winds are from North West and North East direction throughout the year , with average speed of 3.40 m/s .
- The annual average radiation is high , approximately 6.4 Wh / m2.

CLASSIFICATION CLIMATOLOGY													KUALA LUMPUR				
CODE		LEGEND											LATITUDE : 3.149172°N				
Am		A : Tropical											LONGITUDE : 101.705521°E				
		Constant rainfall except some dry month and exaggerated rainfall in some months.											ALTITUDE : 22 m.s.n.m.				
C L I M A T O L O G I C A S	PERIOD	ELEMENTS METEOROLOGICAL	UNITS	JAN	FEB	MAR	APR	MAY	JUN	JUL	AGT	SPT	OCT	NOV	DEC	AVERAGE ANNUAL	
	2017	TEMPERATURE	MAXIMA	°C	34.00	34.00	34.00	34.00	33.00	30.00	29.00	29.00	30.00	31.00	33.00	33.00	32.00
			MEDIA	°C	27.00	28.00	29.00	30.00	29.00	28.00	26.00	26.00	27.00	27.00	28.00	27.00	27.50
			MINIMA	°C	21.00	23.00	23.00	26.00	25.00	23.00	23.00	24.00	24.00	24.00	23.00	22.00	23.41
			OSILACION T°	°C	13.00	11.00	11.00	8.00	8.00	7.00	6.00	5.00	6.00	7.00	10.00	11.00	8.58
	2017	PRECIPITACION	MONTHLY	mm	1.00	0.00	0.00	30.00	248.00	990.00	1054.00	589.00	378.00	217.00	65.00	31.00	300.25
	2017	HUMEDAD RELATIVA	MAXIMA	%	85.00	85.00	85.00	88.00	72.00	86.00	85.00	84.00	83.00	80.00	71.00	61.00	74.17
			MEDIA	%	55.00	55.50	60.00	61.50	65.50	82.50	81.00	81.00	78.00	72.50	63.00	52.50	67.34
			MINIMA	%	44.00	48.00	61.00	55.00	59.00	79.00	77.00	78.00	73.00	65.00	55.00	44.00	60.50
	2017	RADIACION	MONTHLY	kWh/m2	8.80	8.30	8.10	7.20	5.35	5.18	5.38	5.38	5.82	5.97	6.24	5.46	6.40
	2017	HRS DESAL	MONTHLY	hours	N.D	N.D	N.D	N.D	N.D	N.D	N.D	N.D	N.D	N.D	N.D	N.D	
	2017	VIENTO	ORIENTACION	m/s	S	S	S	SE	SW	SW	SW	SSE	SW	SE	SEE	S	
VELOCIDAD			m/s	3.61	3.66	4.16	4.16	3.33	2.77	3.05	4.20	3.60	2.50	2.70	3.05	3.40	

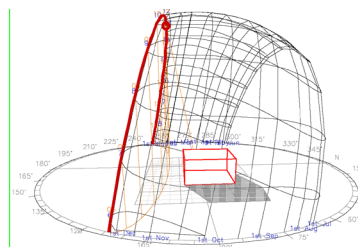

21 JUN

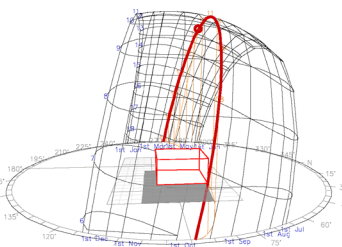

21 MAR / SET

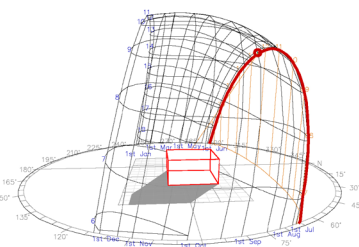

21 DIC



Kuala Lumpur has latitude of 3° degree so the sun falls almost perpendicularly and the environments that are going to be heated are the floors and ceiling. Since Kuala Lumpur is close to the equatorial line there is no winter and summer differentiation, the temperature is throughout the year with very strong solar incidence.

### Ombrothermic graphy

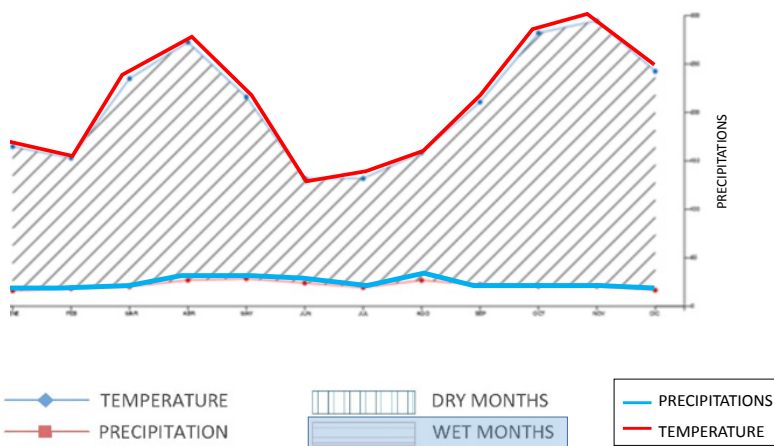

it is a humid climate with rainfall all year

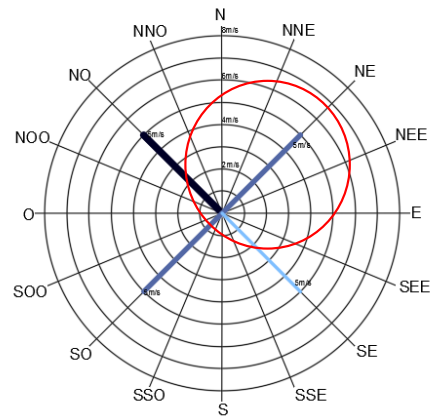

The average velocity of winds is 5 m/s with the direction of more frequent winds of NW (5 months) and NE (3 months) according to the graph

The Giovanni Structural Bioclimatic chart shows that the temperatures and relative humidity are very high and the indoor areas are out of comfort. Only in a few months are inside the comfort zone (but almost at the edge of the comfort zone)

As a strategy it will be necessary to constantly ventilate all indoor areas.

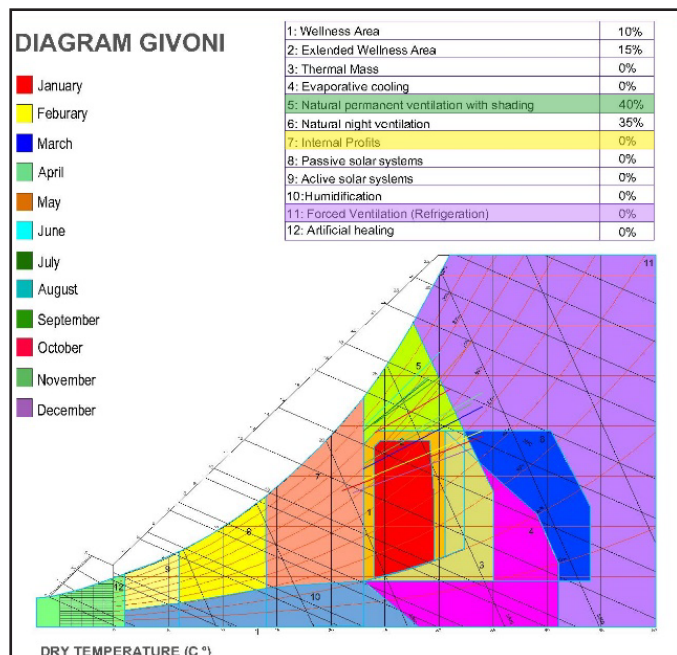

## 5. Evaluation of thermal behavior of GBD tower based on form configuration and construction material used.

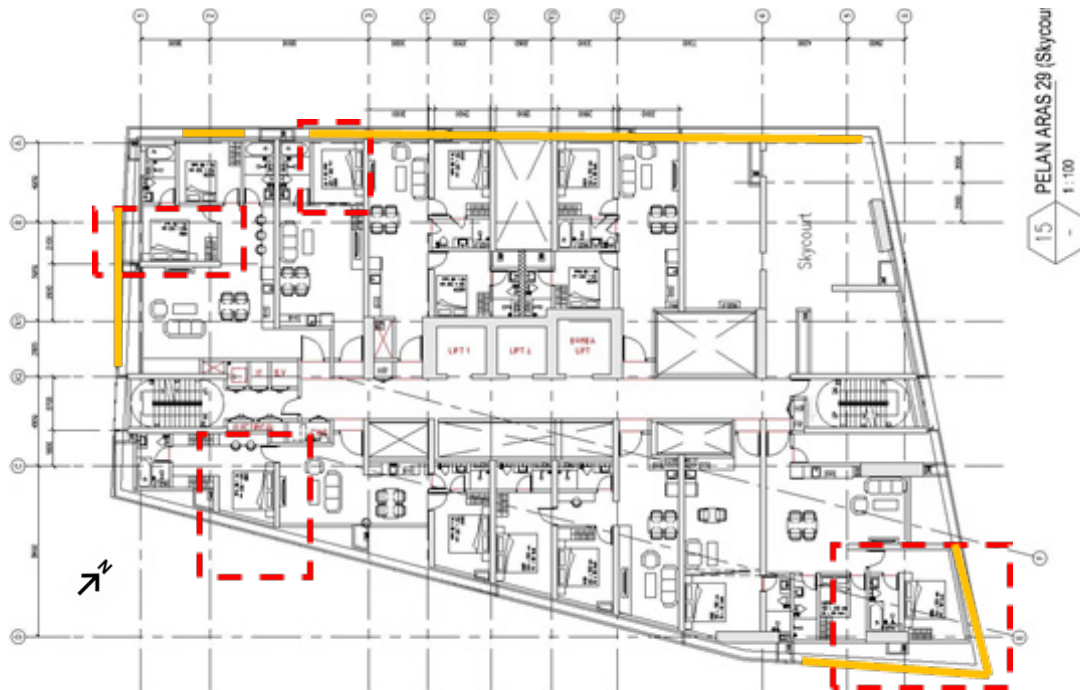

Typical Floor : The environment to be analysed will be the main room of each elevation.

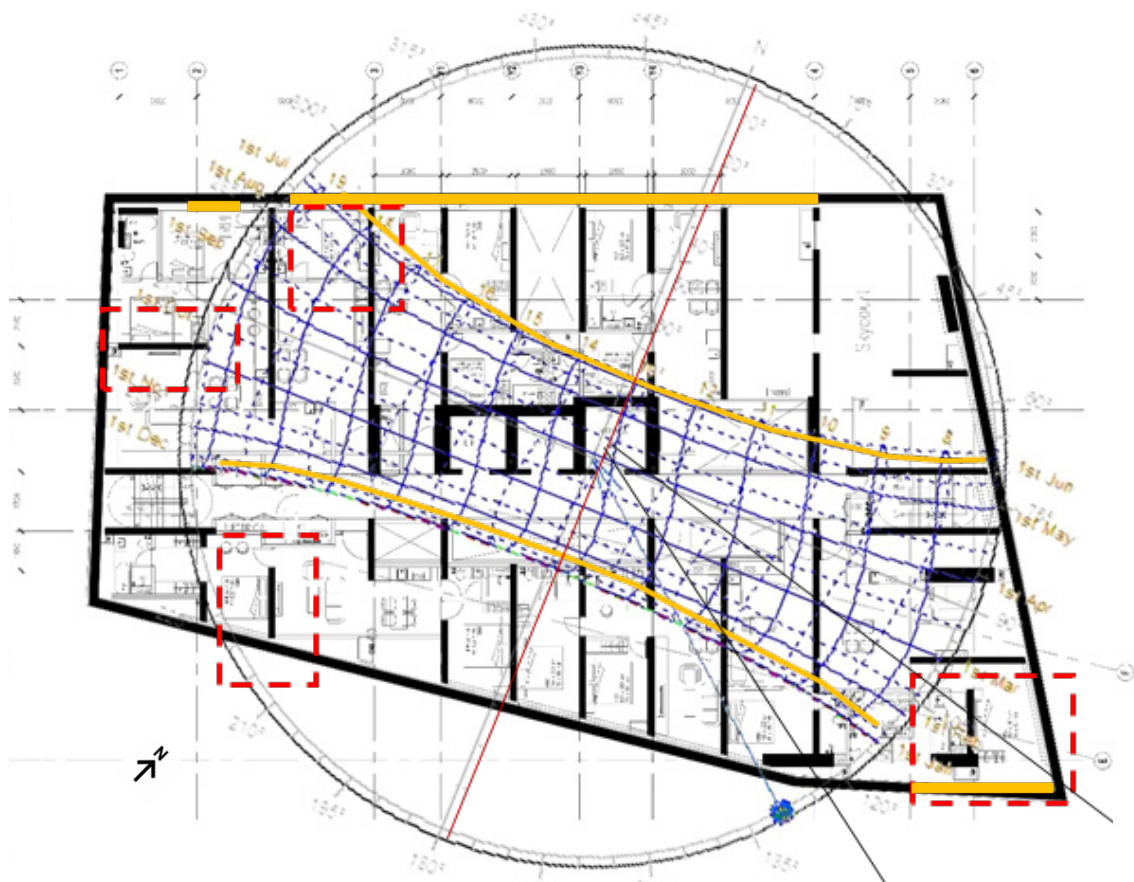

### Legend

- Facade With sun shading
- Typical Floor : The environment to be analysed will be the main room of each elevation.

It can be concluded that the NE facade will receive sunshine in the months of June from 8:00 am until 12:30pm, in the month of May and July from 8:00 am until 12:30 pm, April and August from 8:00 am to 12:50 pm , in March and September will receive sun from 8:00 am until 1:30 pm and finally a little sunshine in the months of February and October from 8 am until 10:00 am.

The facade South will receive the sun in the month of December from 10:30 am until 16:00 pm, Nov and January from 11:30 am to 3:30 pm and finally in the months of February and October from 12:30 pm to 2:30 pm.

The South façade will receive sun from 11:00 am to 4:00 pm the months of December, November and January from 11:30 am to 3:30 pm, February and October from 12:00 pm to 3:00 pm and March and September from 12:30 p.m. until 2:30 p.m. and only one hour of sunshine in the month of April from 1:00 p.m. to 2:00 p.m. in the SW facade will receive sun the months on March / September from 10 p.m. : 00 a.m. until 12:30 p.m., in February and October from 8 a.m. until 11:30 a.m., November and January from 8:00 a.m. until 11:30 a.m. and December from very early 8:00 a.m. until 10:30 a.m.

The NW façade will receive sunshine from mid-day to 7:00 PM in June, in July and May from 12:30 to 7:00 pm, in April and August from 12:40 pm to 7:00 pm The SE façade will only receive sun in the month of December from 8:00 am to 10:30 am , in Nov and January from 8:00 am to 11:30 am, in February and October from 10:00 am to 12:30 pm. We can conclude that the optimal orientation would be the South because it does not receive much direct solar incidence. The most exposed to the sun are NE,NW and SE Facade.

# 05 SOLAR ANALYSIS OF GBD TOWER

## 5.1 Solar impact on walls and floors ( without sun shading)

A comparative analysis has been done on the four sides of the building façades, with and without the sun shade to evaluate the sun penetration inside the building and plotted on the Stereographic chart. The façades oriented towards NE (main) NW, SW,S and SE are taken into consideration for this study. The sun has been evaluated as a whole throughout the year, most part of the building are sunlit with windows orientations at NE ,NW, SW,S and SE.

The below figure shows the stereographic charts for the following façades : NE, SW, NW,S without any Sunshade.

Stereographic Diagram  
Location : 3.1° , 101.7°  
Obj 252 Orientation : 0.0°,0.0°  
Sun Position : 104.7° , 77.0°  
HSA : 104.7°  
VSA : 93.4°

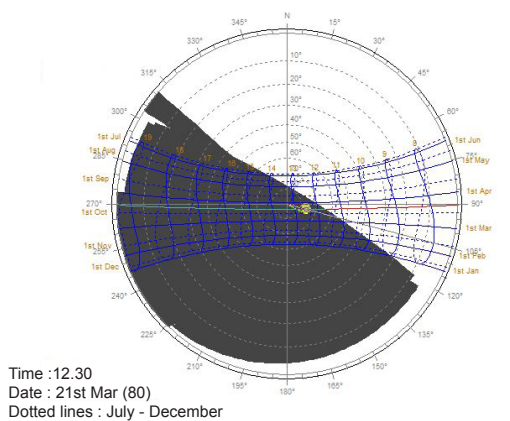

Figure 5a. Stereographic Diagram for windows at NE without Sun Shading (Solar Obstruction)

Stereographic Diagram  
Location : 3.1° , 101.6°  
Obj 16641 Orientation : 0.0°,0.0°  
Sun Position : -118.9° , 28.4°  
HSA : 173.7°  
VSA : 151.5°

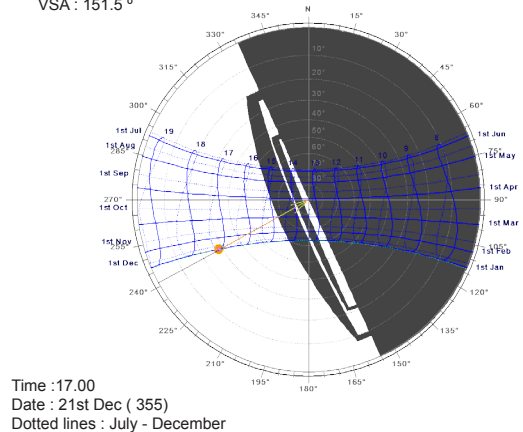

Figure 5b : Window SW without Sun Shading

Stereographic Diagram  
 Location : 3.1° , 101.6°  
 Obj 16849 Orientation : 0.0°,0.0°  
 Sun Position : -118.9° , 28.4°  
 HSA : -118.9°  
 VSA : 131.8°

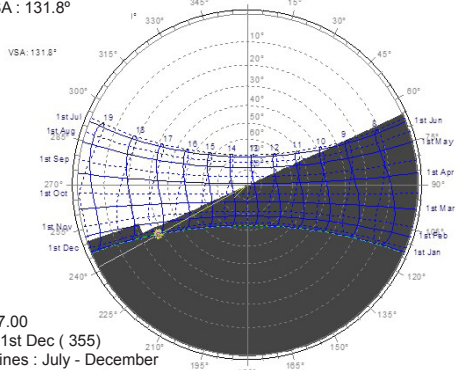

Figure. 5c: window NW Windows without Sun Shading

Stereographic Diagram  
 Location : 3.1° , 101.6°  
 Obj 16849 Orientation : 0.0°,0.0°  
 Sun Position : -118.9° , 28.4°  
 HSA : 83.7°  
 VSA : 78.4°

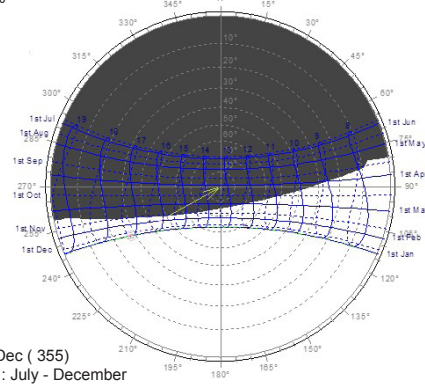

Figure. 5d : window S without Sun shading

At 9:00 a.m and 17:00 pm, the impact of the sun falls almost horizontally inside the building environments with a inclination of 40° degrees or greater heating the vertical surfaces rather than the horizontal ones. Floor plate receive strong vertical sun impact for at least 5 hours with vertical sun and the rest of the day the impact is less due to the inclination of the sun .

Stereographic Diagram  
 Location : 3.1° , 101.6°  
 Obj 16849 Orientation : 0.0°,0.0°  
 Sun Position : -118.9° , 28.4°  
 HSA : 83.7°  
 VSA : 78.4°

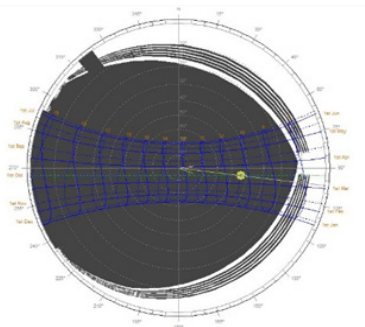

Figure . 5e. sunning windows SW (solar obstruction)

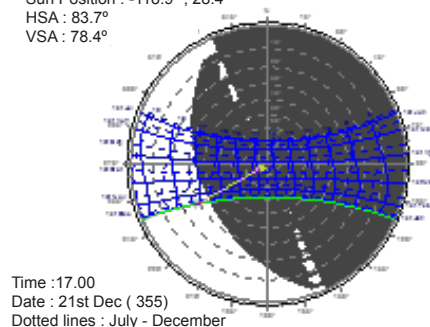

Figure. 5f: window NW,NE with sunshading

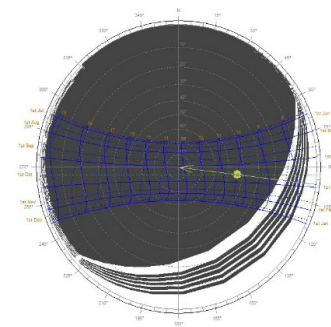
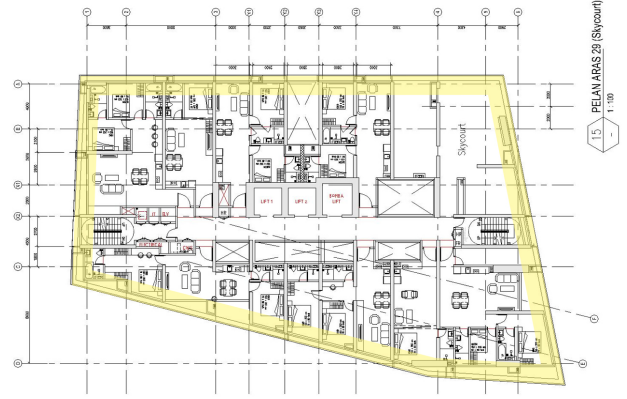
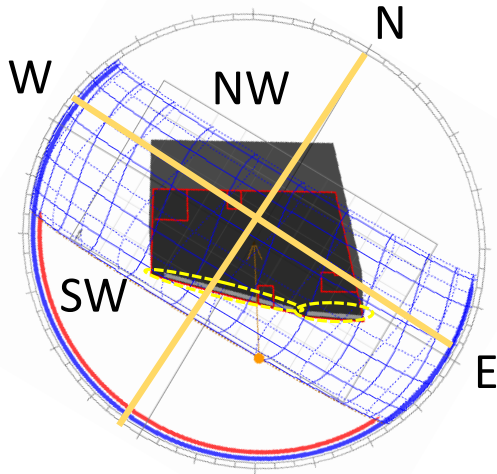

Figure. 5g: window SE and NE Windows with Sun Shading

The openings oriented to the NW allow the sun to penetrate in the afternoons from approximately 2:00pm to 6:00 pm, the openings oriented to the NE allow the penetration of the Sun in the mornings the year, the openings oriented to the SW allow the solar penetration the afternoons from 2 pm to 6 pm . Approximately in the months of December, January , November, February , October, March and September, The South façade allows the solar penetration in the mornings of the months of December.

# 5.1.



Solar analysis has been done on all the facades , with and without sun shades to evaluate the sun penetration inside the building and it has been plotted on the stereographic chart.

The below figure shows the stereographic charts for the following façades : NE, SW, NW,S without and with sun shading .

Stereographic Diagram  
 Location : 3.1° , 101.6°  
 Obj 16849 Orientation : 0.0 °,0.0 °  
 Sun Position : -118.9 °, 28.4 °  
 HSA : -118.9 °  
 VSA : 131.8°

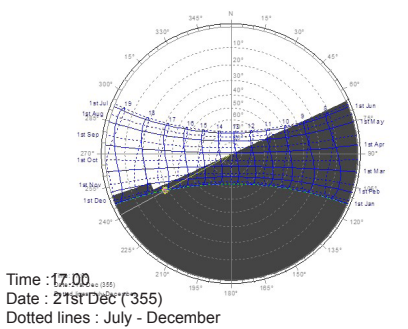

Figure 5c: window NW Windows without Sun Shading

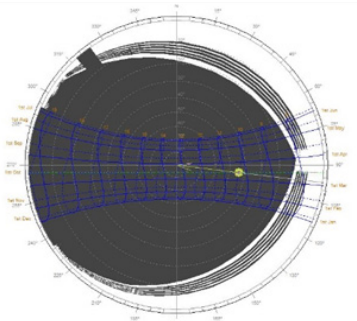

Figure 5e. sunning windows SW with sun shading

Stereographic Diagram  
 Location : 3.1° , 101.7°  
 Obj 252 Orientation : 0.0 °,0.0 °  
 Sun Position : 104.7 °, 77.0 °  
 HSA : 104.7 °  
 VSA : 93.4 °

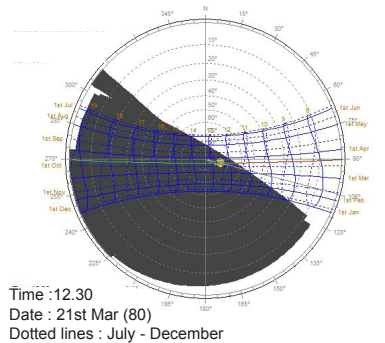

Figure 5a. Stereographic Diagram for windows at NE without Sun Shading



Stereographic Diagram  
 Location : 3.1° , 101.6°  
 Obj 16849 Orientation : 0.0 °,0.0 °  
 Sun Position : -118.9 °, 28.4 °  
 HSA : 83.7°  
 VSA : 78.4°

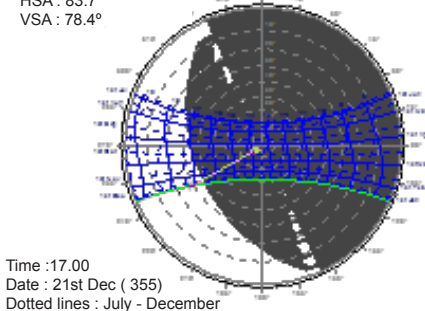

Figure 5f: window NW,NE with sunshading

Stereographic Diagram  
 Location : 3.1° , 101.6°  
 Obj 16849 Orientation : 0.0 °,0.0 °  
 Sun Position : -118.9 °, 28.4 °  
 HSA : 83.7 °  
 VSA : 78.4°

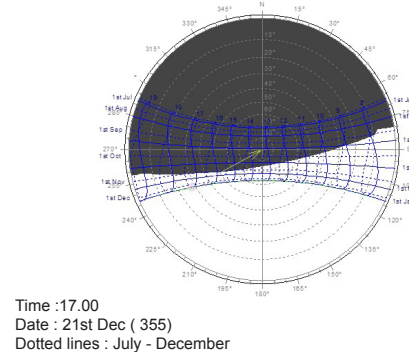

Figure 5d : window S without Sun shading

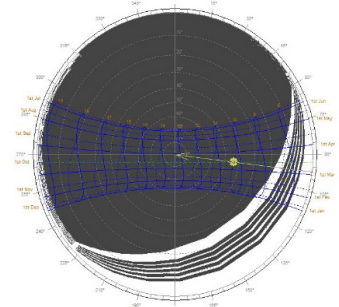

Figure 5g: window SE and NE Windows with Sun Shading

## 5.1.2 Shadow Analysis

21 MARCH/ SEPTEMBER

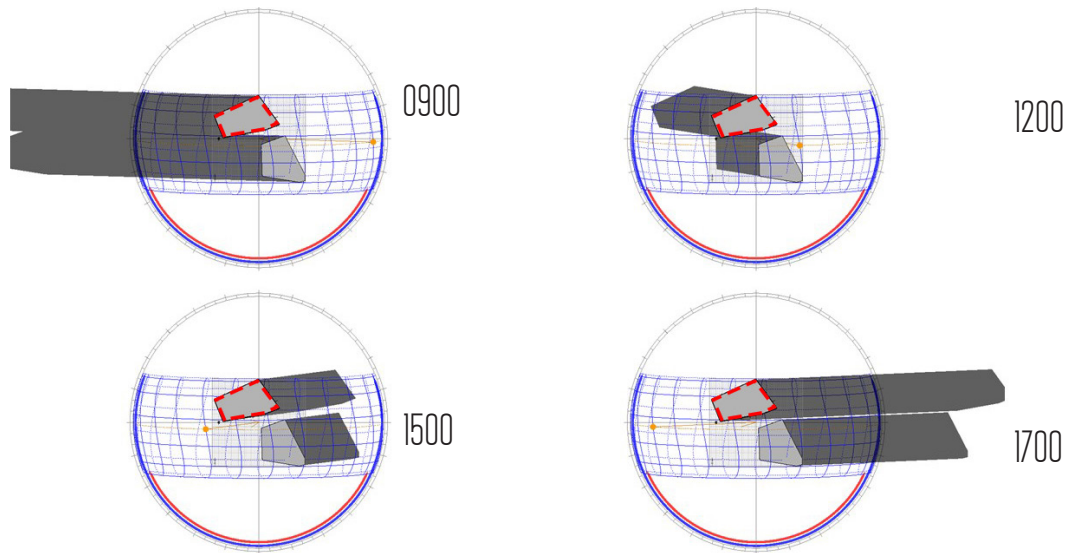

Figure 5.1a shadow Analysis on 21 March and September

The shadows casted day the adjoining building will affect the Southern façade, especially in the mornings. It will affect only the the 30 first floors of the Project since the adjoining building is smaller.

21 JUNE

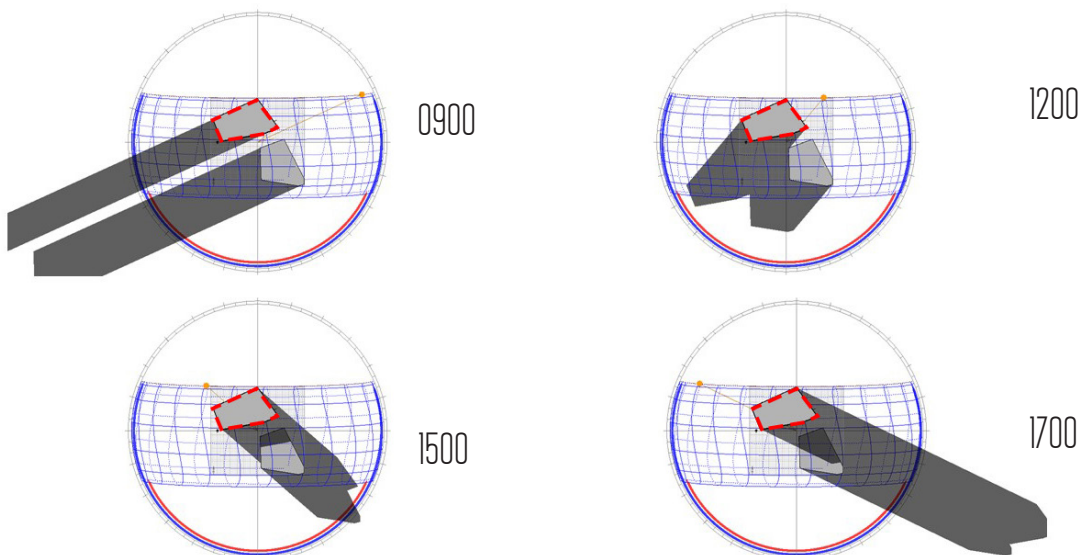

Figure 5.1b shadow Analysis on 21 June

Shadows casted from the adjoining building will obstruct the penetration of the sun on the south facade of the GBD tower from noon to evening. For this reason, it is not necessary to add solar protection on the southern façade. Since the first 30 floors will have a solar obstruction. From the 30th floor to the 40th floor there will be no solar obstruction, however, the solar incidence will be a maximum of 1.5m inside the rooms (information analysed in the next point of the solar analysis).

21 DECEMBER

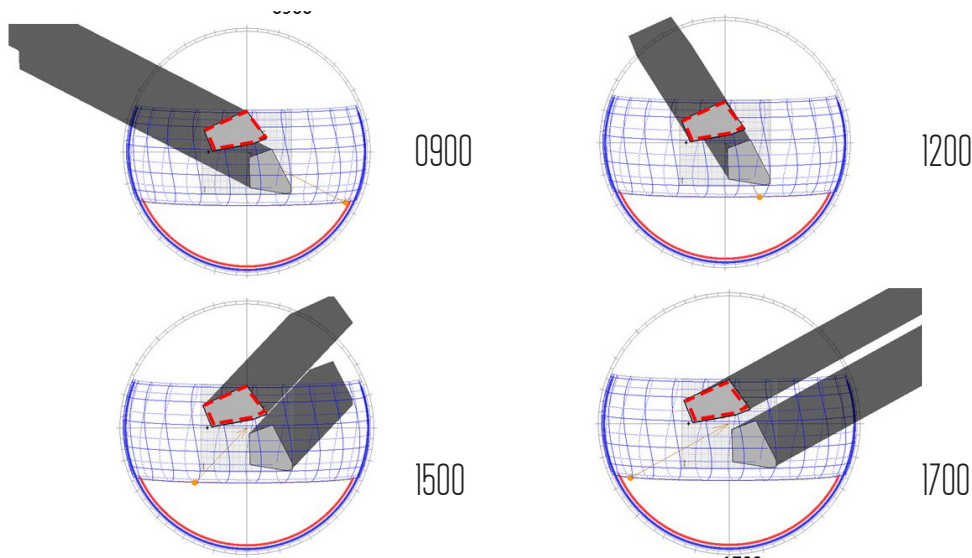
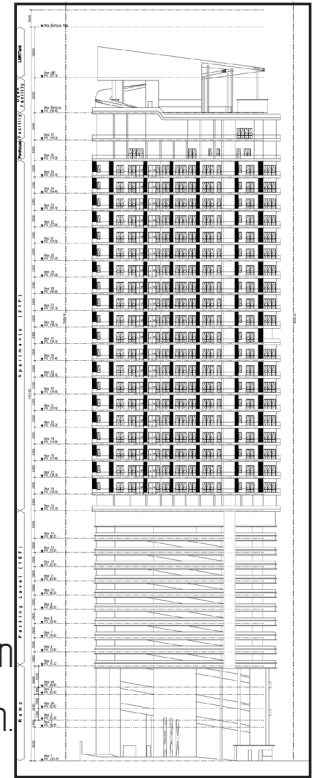

Figure 5.1 c shadow Analysis on 21 December

Shadows casted from the adjoining building will obstruct the entrance of the sun on the South facade and SW facade of the GBD tower from 8:00 am to 1.00pm.



South Facade

## 5.2 Solar Penetration to Buildings

- Penetration of the sun without solar protection .
- The openings that allow the sun penetration are large, the majority is 2.00 meter and have lintel 77cm placing in the upper part of the wall

### Solar penetration on 21 March and September

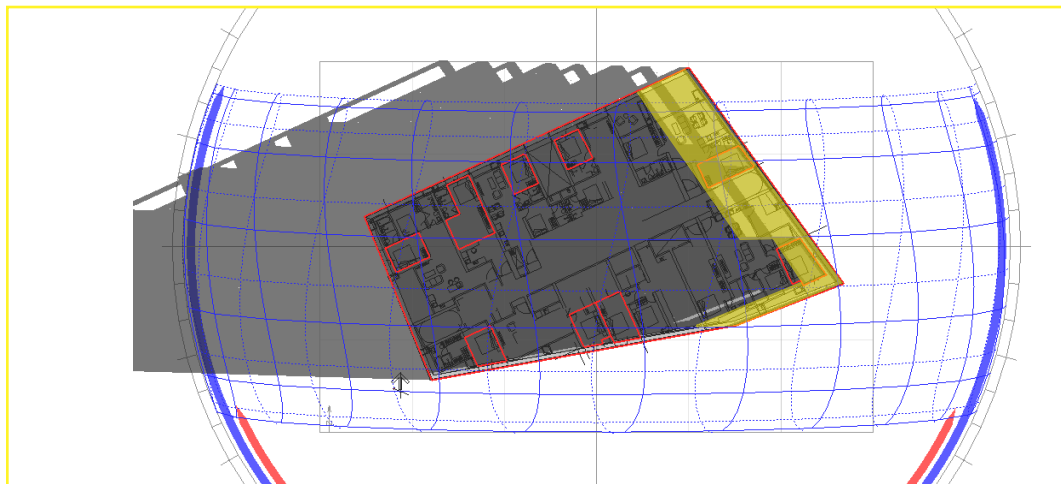

5.4d Typical floor plan Solar penetration on 21 March and September

Typical floor plan with sun-penetration inside the building at 0900 am on 21 March. The most affected part will be the NE Facade as it will have greater solar direct penetration. Additional vertical solar protection is needed on NE facade.



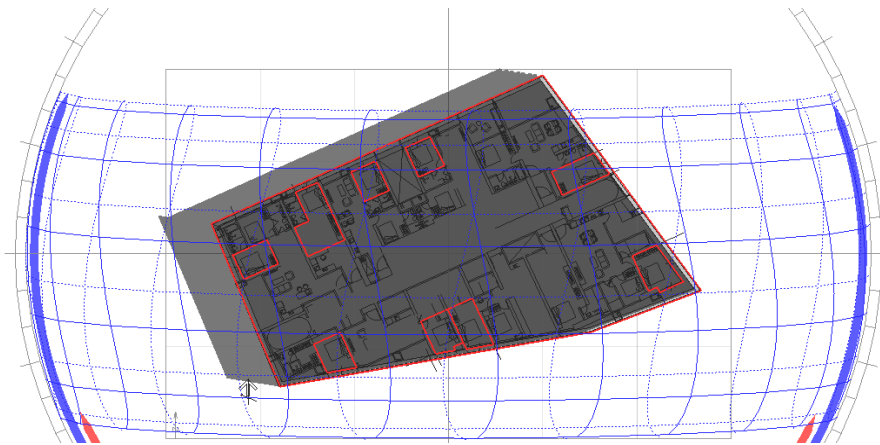

Figure 5.4e Typical floor plan Solar penetration on 21 March and September

Typical floor plan with sun-penetration inside the building at 1200pm on 21 December. In general there will be no problem with the solar penetration at any month of the year at 12 am as the sun is almost vertical and almost directly falls to the roof of the building.

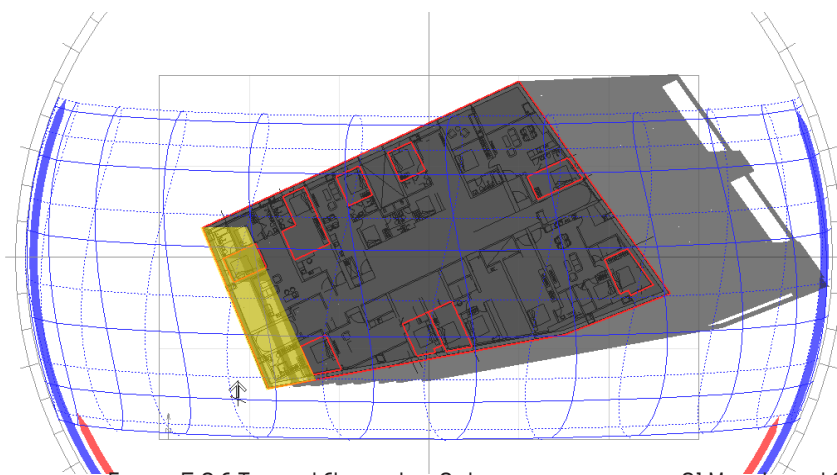

Figure 5.2 F Typical floor plan Solar penetration on 21 March and September

Typical floor plan with sun-penetration inside the building at 17:00pm on 21 March. The SW facade will receive a direct solar impact which would cause glare and discomfort. It is necessary to add vertical solar protection sun shading in the SW facade.

## Solar Penetration 21 June without sun shading

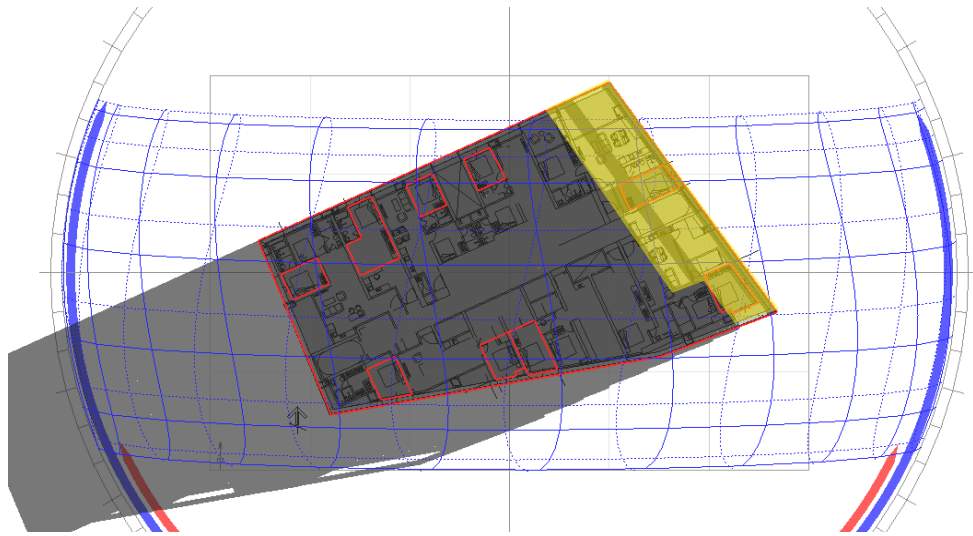

Figure 5.2g Typical floor plan Solar penetration on 21 June

Typical floor plan with sun-penetration inside the building at 09:00 on 21 June. At this hour the direct solar income will differ and will affect the bedrooms on the NE and SE façades. It is necessary to place a vertical solar protection on these façades.

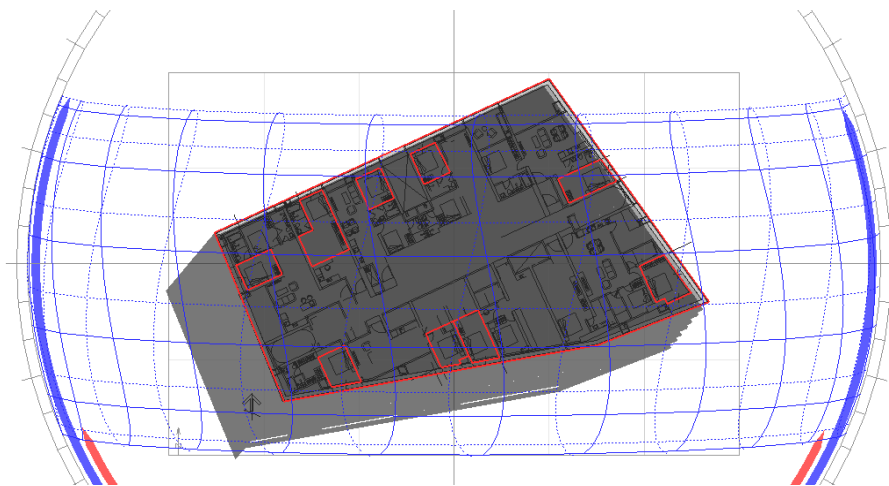

Figure 5.2 h Typical floor plan Solar penetration on 21 June

Typical floor plan with sun-penetration inside the building at 1200pm on 21 June. in general there will be no problem with the solar penetration at any month of the year at 12 am as the sun is almost vertical and almost directly falls to the roof of the building. However at 12pm it is penetrating the NE facade almost 2 meters of solar incidence.

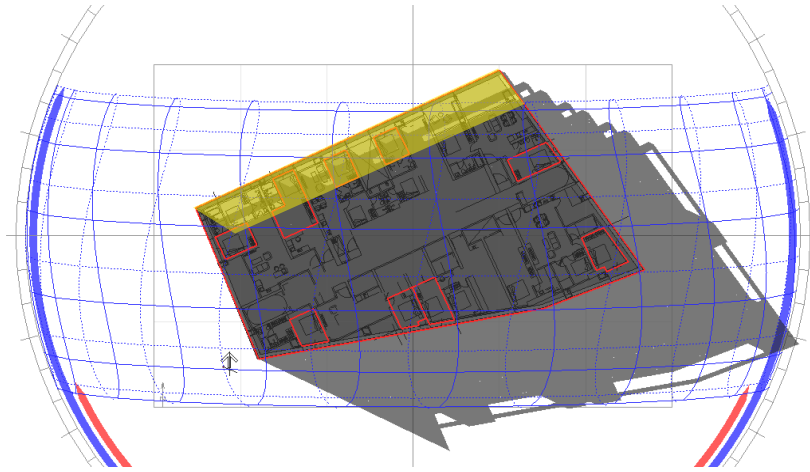

Figure 5.2 i Typical floor plan Solar penetration on 21 June

Typical floor plan with sun-penetration inside the building at 17:00pm on 21 June. there is a direct solar penetration that will cause glare and discomfort on the NW facade. NW facade will need vertical solar protection.

### Solar penetration on 21 December

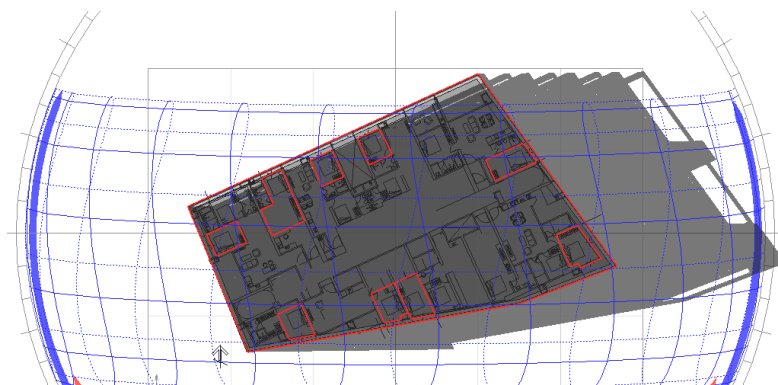

Figure 5.2 a Typical floor plan Solar penetration on 21 December

Typical floor plan with sun-penetration inside the building at 0900 am on 21 December. The graph explains that the sun penetrated into the building the NE façades is causing discomfort approximately 4m inside the interior. It is necessary to place solar protection on the NE facade.

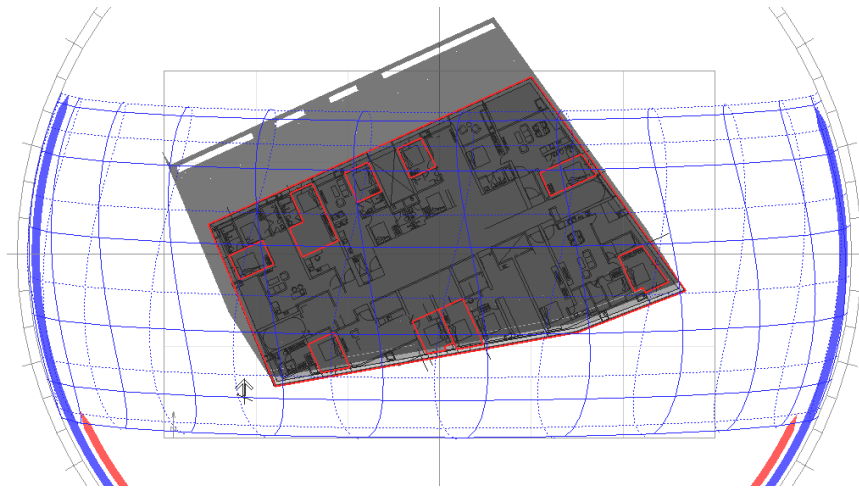

Figure 5.2 b Typical floor plan Solar penetration on 21 December

Typical floor plan with sun-penetration inside the building at 1200pm on 21 December. In general there will be no problem with the solar penetration at any month of the year at 12 pm as the sun is almost vertical and almost directly falls to the roof of the building

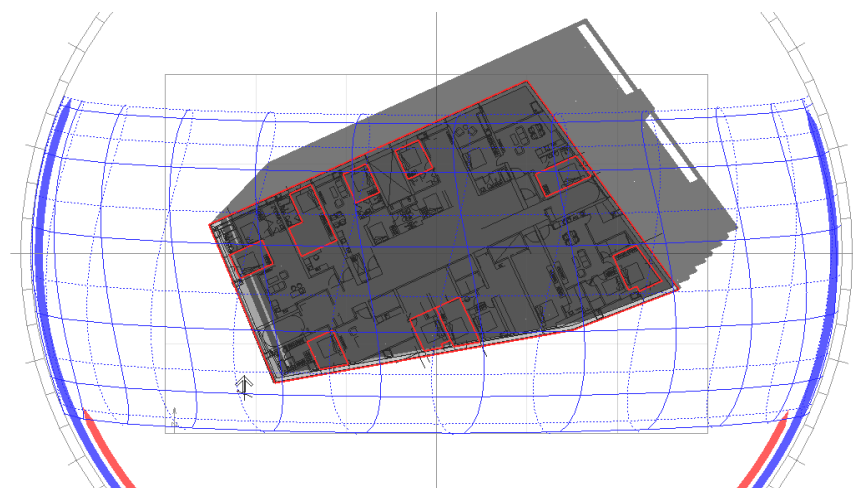

Figure 5.3 c Typical floor plan Solar penetration on 21 December

Typical floor plan with sun-penetration inside the building at 17:00pm on 21 December. The SW façade will receive the full impact of the sun. It is necessary to include in the design a vertical solar protection. On the south facade it is not necessary to place sun protection since the entrance of the sun is controllable by the large balconies.

## Conclusion

The openings oriented to the NW and SW allow the sun to enter in the afternoon from 2:00 p.m. to 5:00 p.m. Most of the incidence or internal solar penetration occurs in the evenings on these façades, which also causes the wall to warm up which would cause higher internal temperatures and therefore discomfort. The openings on the NE facade allow the penetration of the sun in the morning. The openings oriented to the SE the allow penetration in the morning.



The most affected are NE , NW,SW and SE façades because there will be direct impact of the sun in the morning and afternoons hours where the sun falls almost horizontally creating a discomfort and glare. It is very important to use a sun shading to prevent penetration of too much direct sun inside the building. The solar incidence of the 12:00 pm is not a problem because it falls almost perpendicularly to the roof surface without causing solar incidence inside the building. In the South facade the entrance of the sun is controllable by the large balconies that are designed on that facade. It is not necessary to place vertical sun protection since the solar penetration is only 2meters inside the building.

### 5.2.1 Solar Penetration inside the room

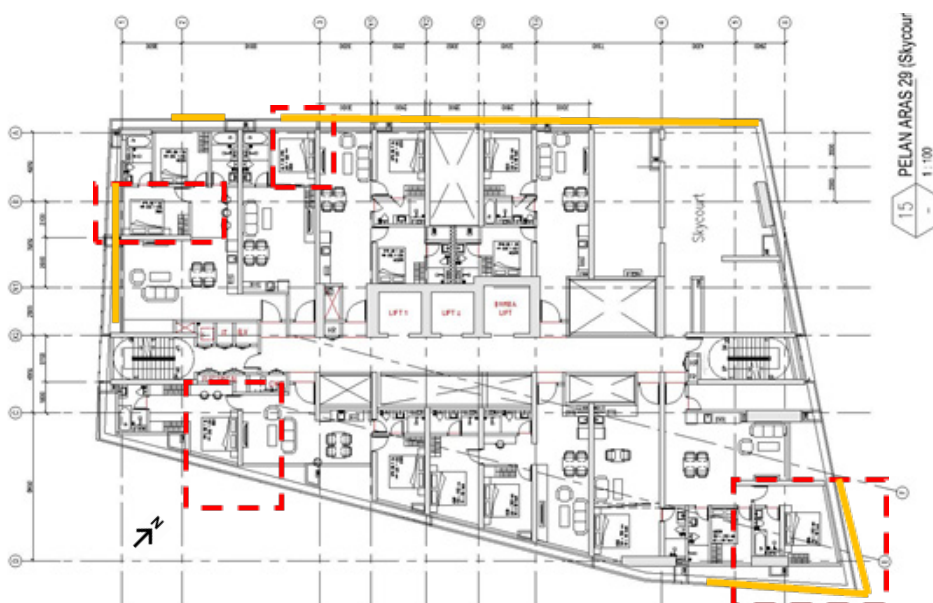
A comparative analysis has been done on the rooms of the building on the four façades, with and without the sun shades to evaluate the sun penetration inside the building and it has been plotted on the Stereographic chart. The façades oriented towards NE (main) NW, SW,S and SE are taken into consideration for this study.



#### Legend

-  Facade With sun shading
-  Typical Floor : The environment to be analysed will be the main room of each elevation.

Typical Floor : The environment to be analysed will be the main room of each elevation.

## Solar penetration on the NE façade

Section of the room NE façade

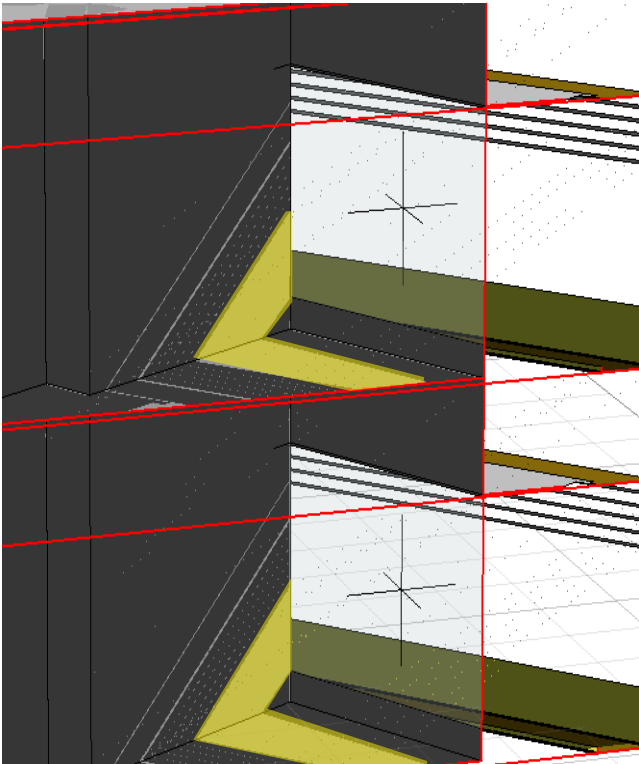

Figure 5.2.1a: the sun penetration in the morning at 9:00 am with sun shading

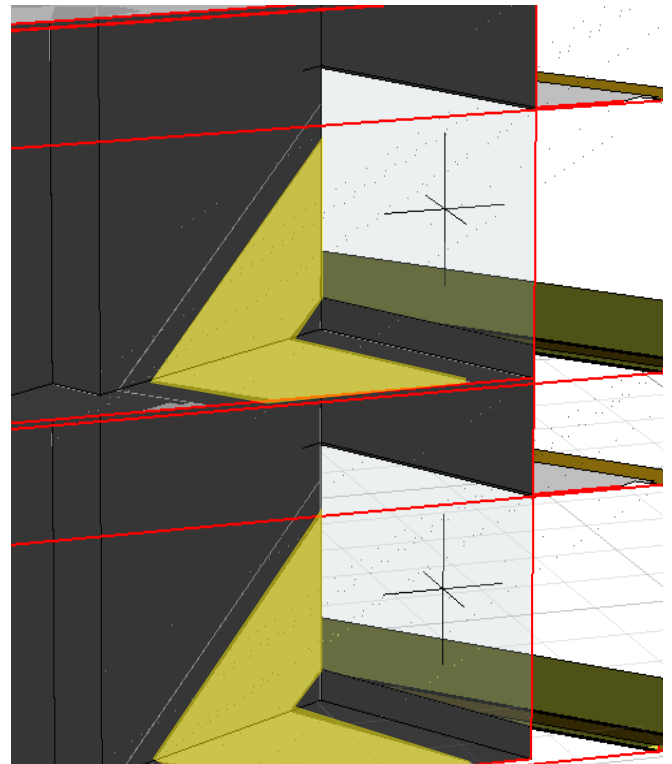
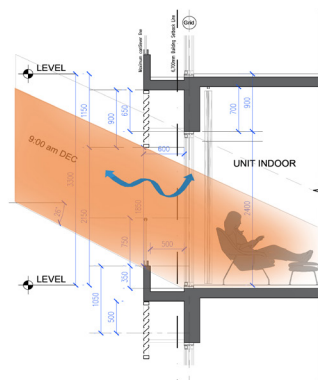
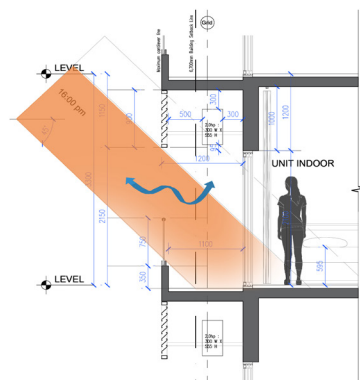

Figure 5.2.1 b : the sun penetration at 9:00 am without sun shading.

Without Sun shading it is going to be more than 50% direct solar penetration inside the room so it is going to cause glare and discomfort



21 NE Sun Shading



21 NW Sun Shading

Figure 5.2.1.c Typical section of the Living ,Dining and Bedroom

# Solar penetration on the NE façade

## Section of the room NE façade

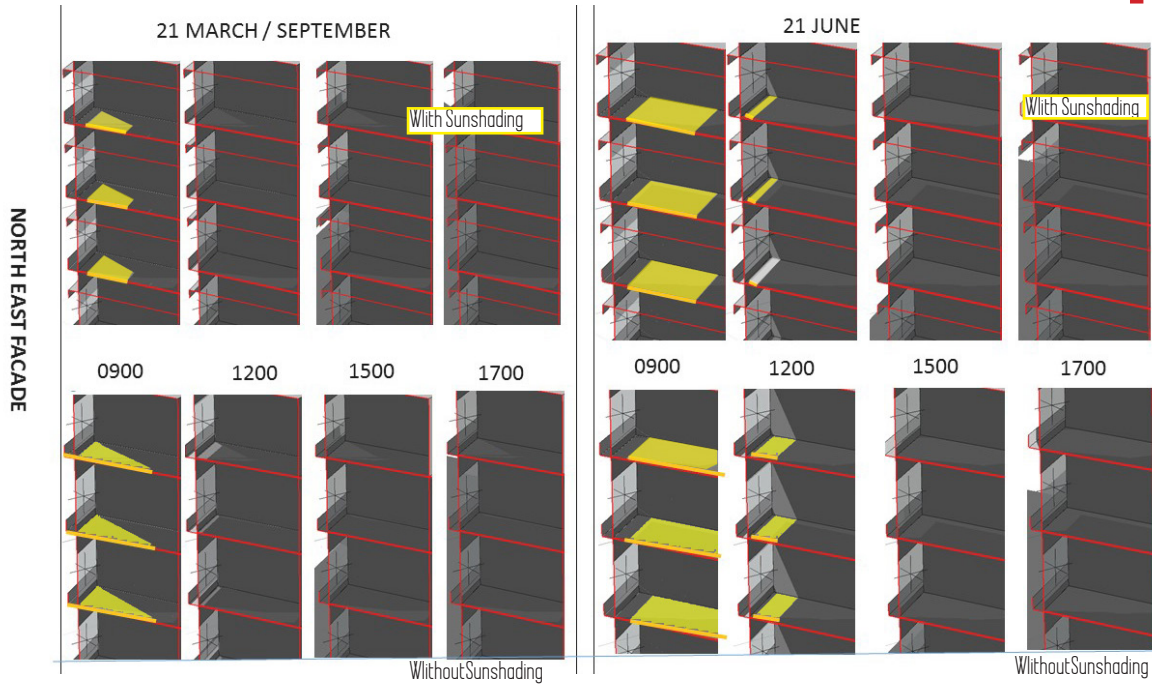

Figure 5.2.1.d Section of the room NE façade

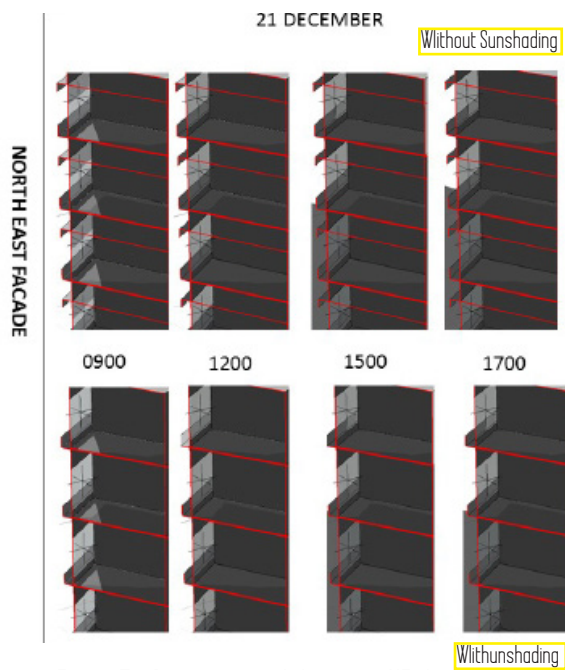
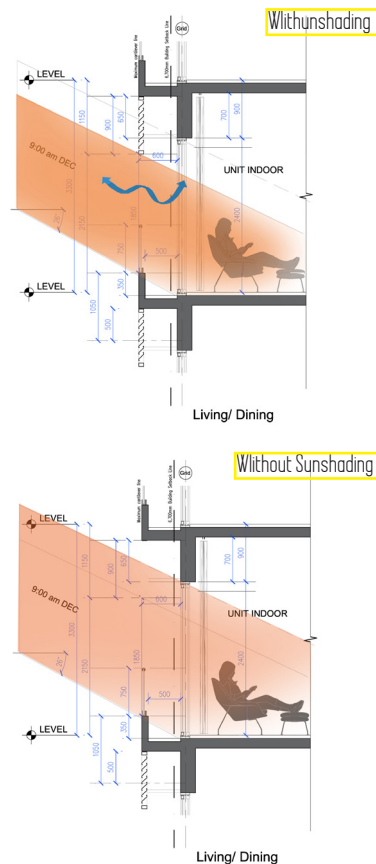

Figure 5.2.1.e Section of the room NE façade

Without sunshading it is going to be more than 45 % direct solar penetration



Section of the room NE façade

Figure 5.2e : the sun penetration in the morning at 9:00 am, 12 pm, 15:00 pm and 17:00 pm on 21 March and September, 21 June and 21 December. In this façade, the solar income is given in the morning, accentuating from 9:00 a.m. in the months of 21 March and September, 21 June and 21 December. The penetration of the sun in the morning hours is almost horizontal, which causes discomfort and glare. You can clearly tell the difference between the sun-protected room and the one with no sun protection. The solar incidence values in the environments without sun protection are approximately greater in 45% in comparison to the façade that has solar protection, which would generate a direct solar incidence, discomfort and glare in addition to elevating the internal temperature (that data we will see later).

### Solar penetration on the NW façade

#### Section of the room NW Facade

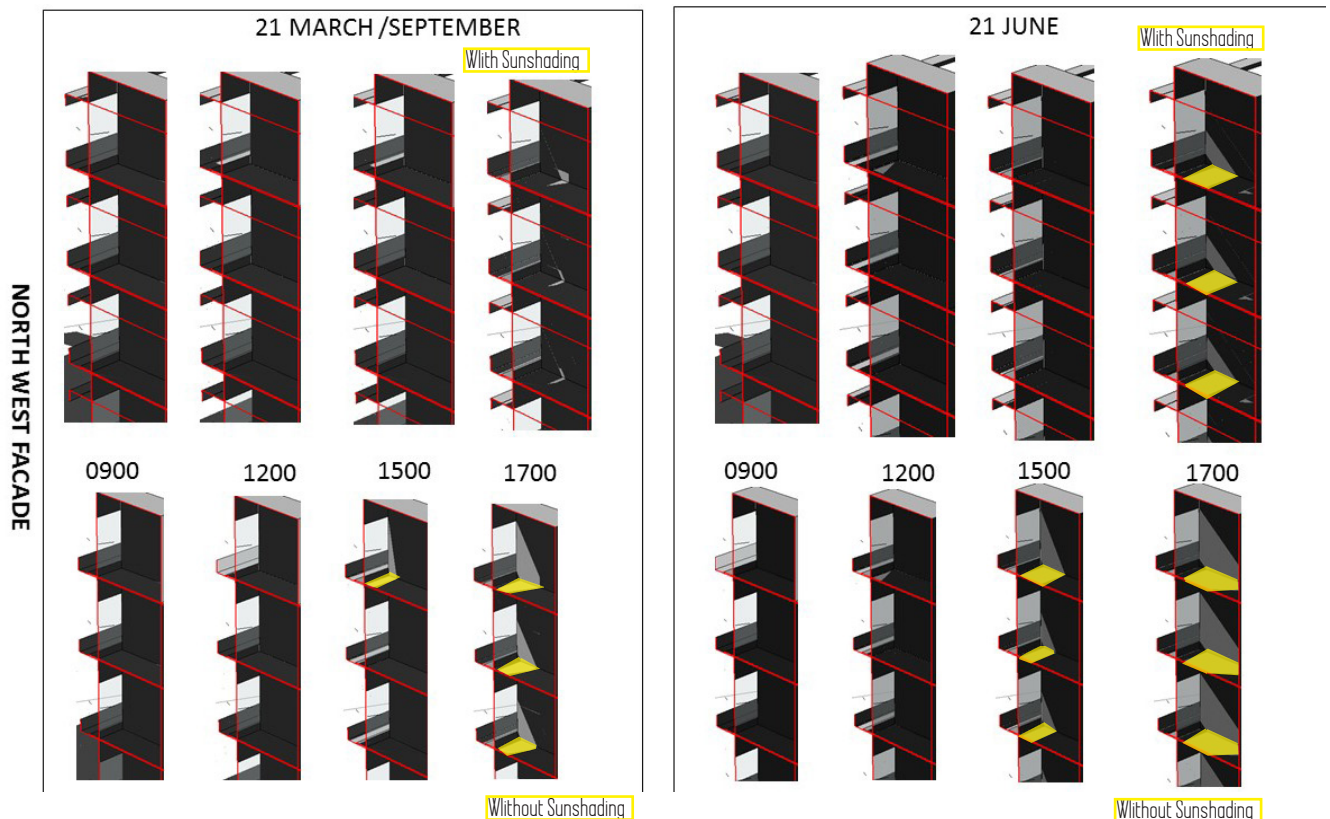
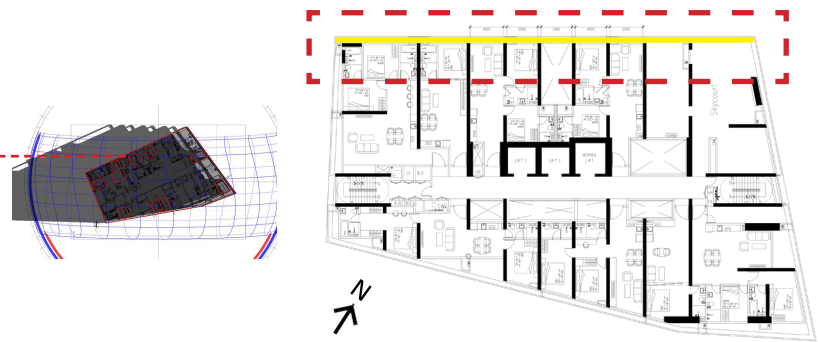



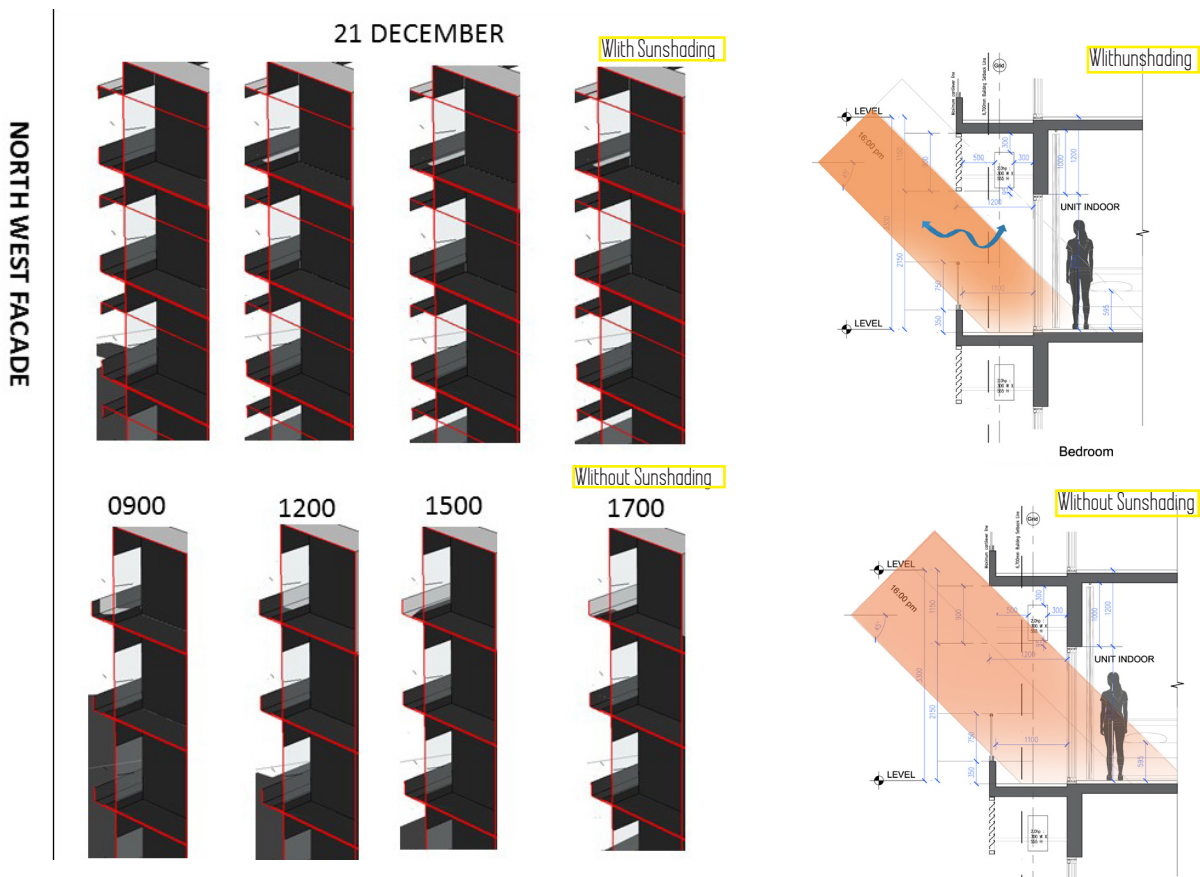

Figure 5.2.1.g Section of the room NW façade

Without sun shading there is more than 50 % of direct solar penetration .

Section of the room NW façade

The direct solar penetration in the NW façade is mostly in the evenings during the whole year. Solar incidence with sun protection is approximately 50 % direct light.

On the NW facade without sun protection the solar income is accentuated causing an overheating of the indoor areas since the evenings sun is the most prejudicial especially in the months of March , September and June from 3:00 pm to 6:00 pm where the solar incidence is greater causing discomfort. In addition to overheating it will cause glare.

# Solar penetration on the SOUTH façade

## Section of the room S Façade

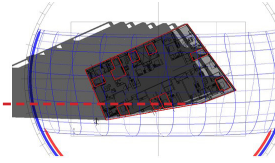

# Solar penetration on the South façade

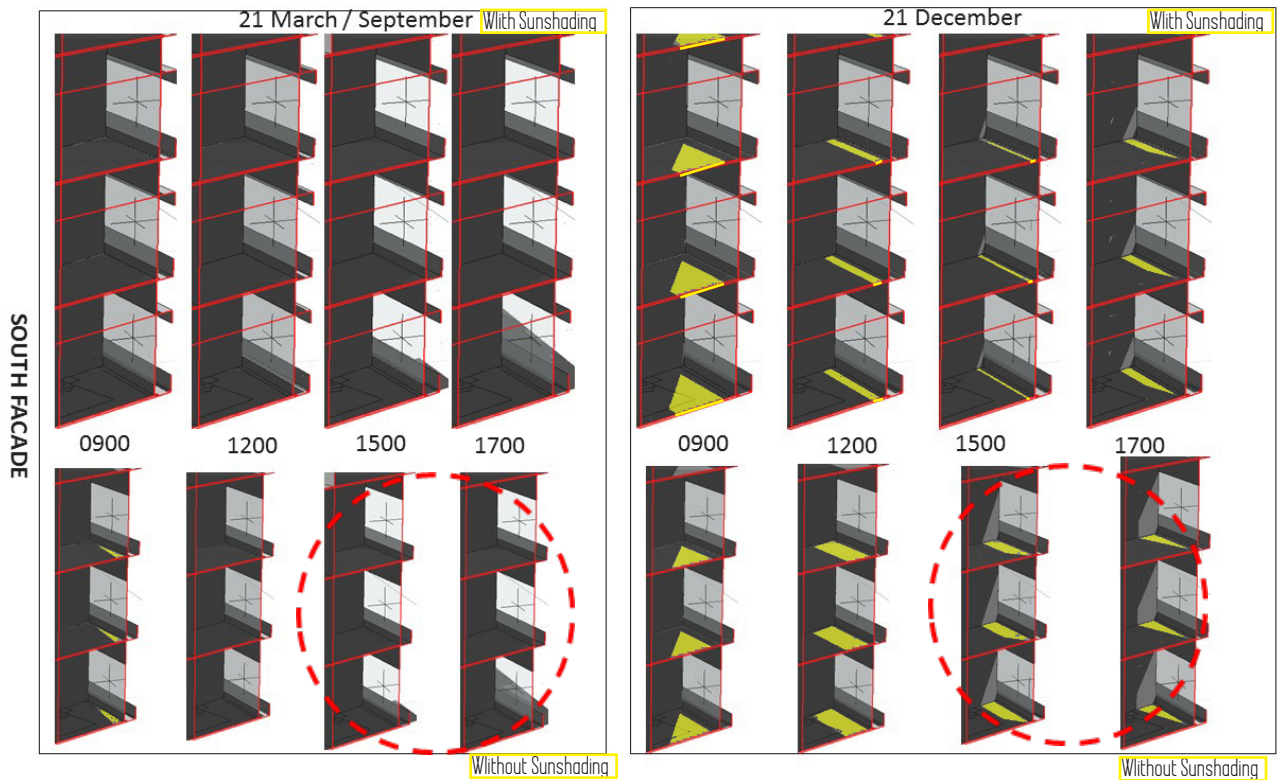

Figure 5.2.1.h Section of the room South façade

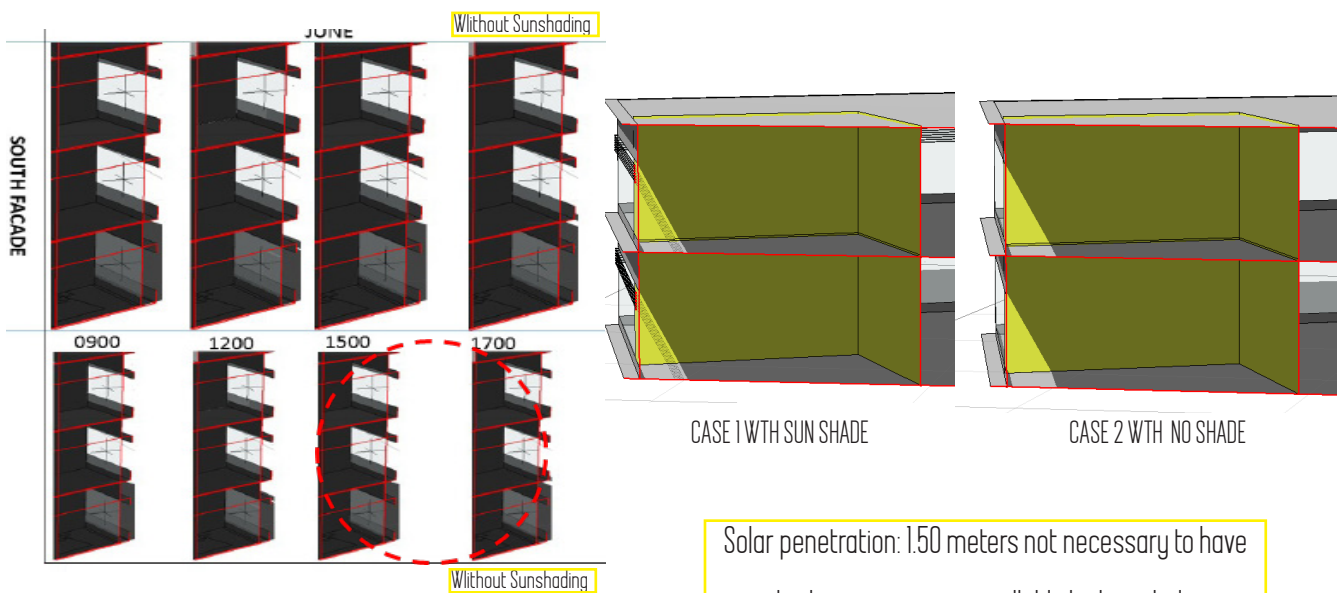

Figure 5.2.1.i Section of the room South façade

Solar penetration: 1.50 meters not necessary to have sun shading since it is controllable by large balconies

According to the solar penetration charts on the South Facade for the months of June , March , September and December from 9:00 a.m, 12:00 p.m. and 5:00 p.m, it can be concluded that sun penetration will be highest in the month of December from 12:00 to 18:00 pm and will be of approximately 1.50 meter of length, which does not cause problem since it is controllable. On the south facade there are large balconies that will be protecting the direct solar penetration to the indoor areas.

### Solar penetration on the SW façade

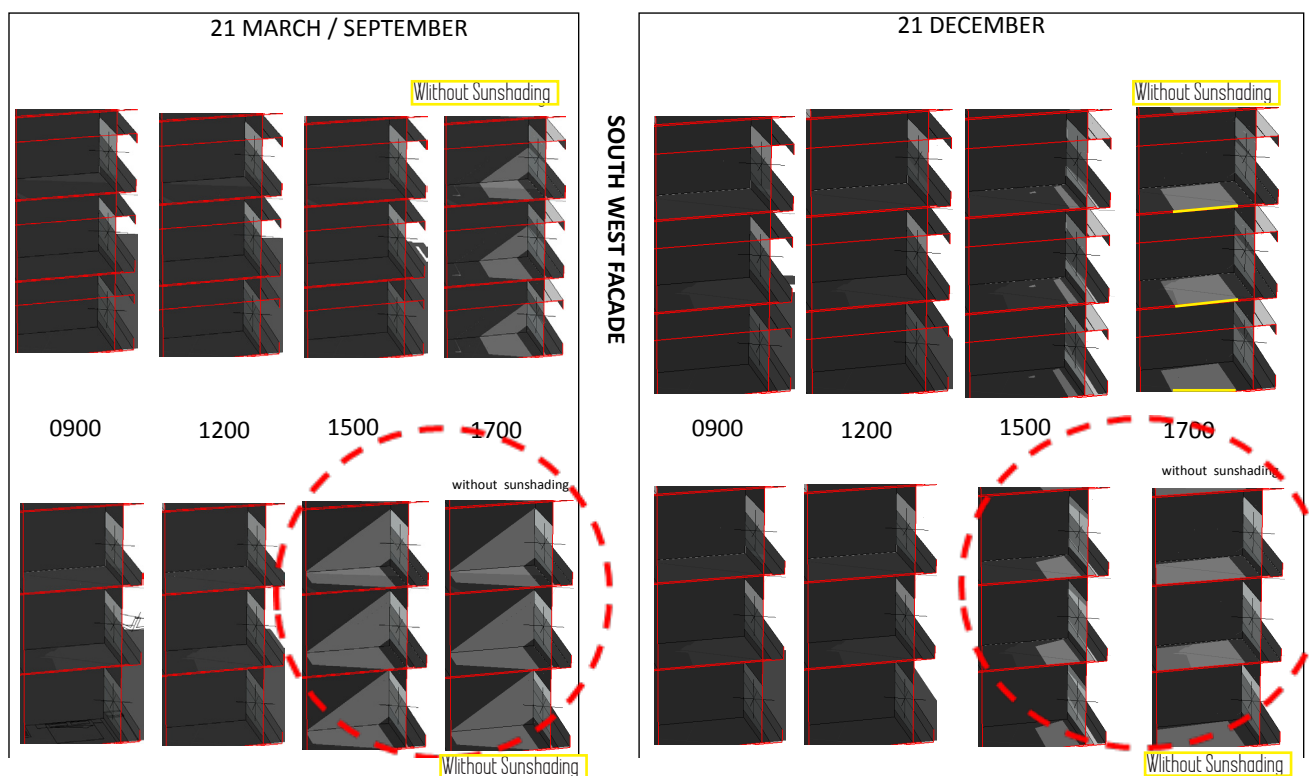
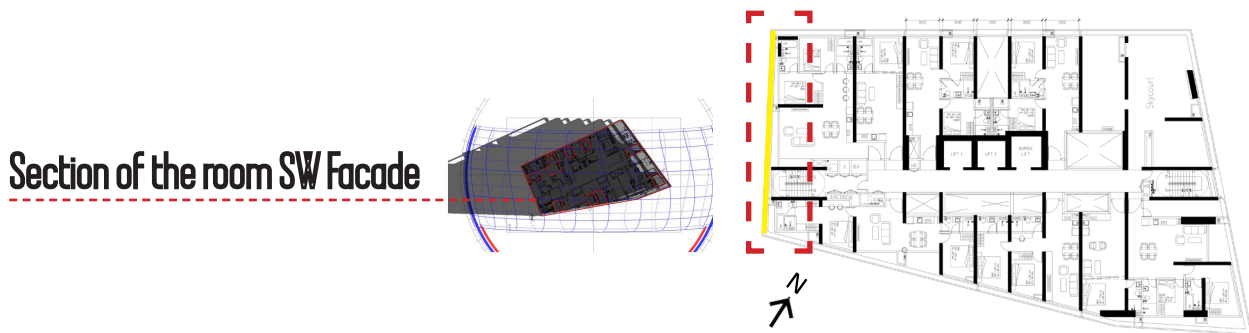

Figure 5.2.1; Section of the room South façade

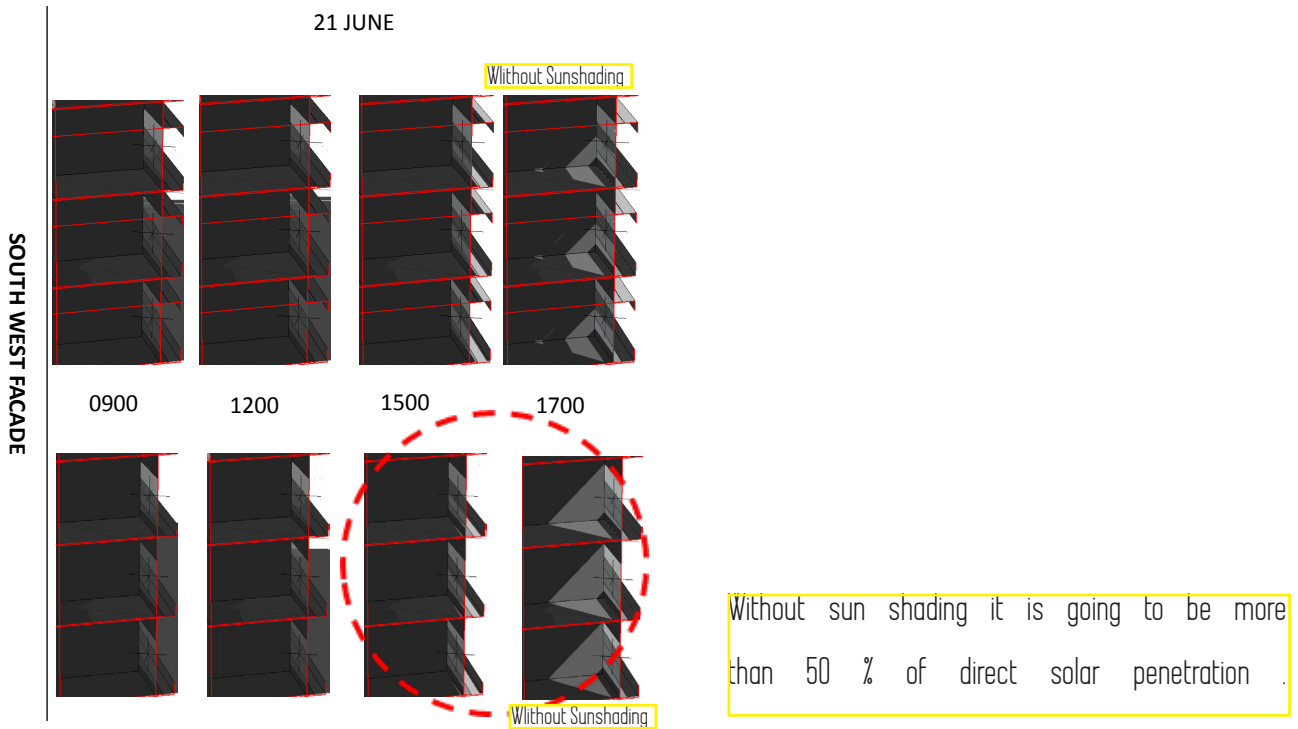

Figure 5.2.1.k Section of the room South façade

The direct solar penetration on the SW façade is mostly in the evenings during the whole year. The penetration at 17:00 pm in the afternoon is almost horizontal, causing the indoor areas discomfort. The direct solar penetration in the NW façade is mostly in the evenings during the whole year. Solar incidence with sun protection is approximately 50 % direct sun light.

On the SW facade without sun protection the solar income is accentuated causing an overheating of the interior areas since the evenings sun is the most prejudicial especially in the months of March, September and June from 3:00 pm to 6:00 pm where the solar incidence is greater causing discomfort. In addition to overheating it will cause glare.

## Sections with and without sun shading

Dec altitude	Dec azimuth	June 21 altitude	June 21 azimuth	March	Sep 21 altitude	March sept azimuth
9:00	25.8	116	26.4	67	65.9	100.1
12:00	65.9		62.8		22.8	
16:00	40	-121.9	45.2	-61.8	49.9	-106.5

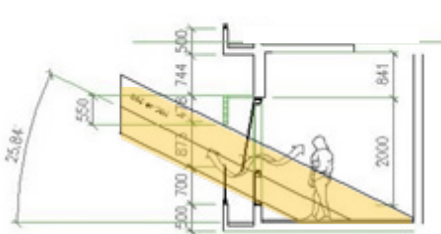

21 SOUTH EAST WITH SUN SHADING

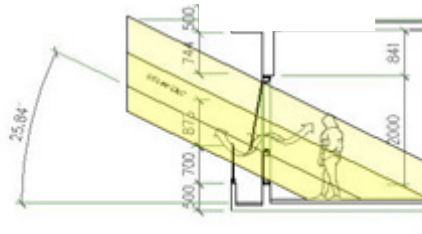

21 SOUTH EAST WITHOUT SUN SHADING

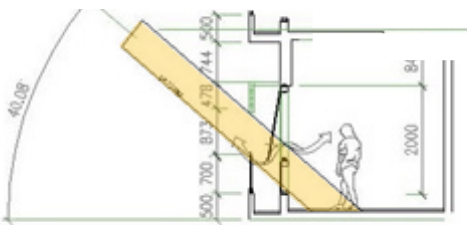

21 SOUTH WITH SUN SHADING

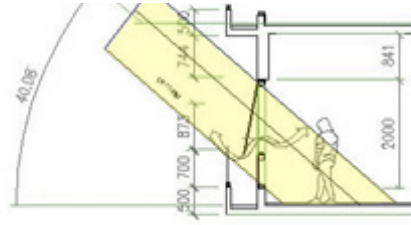

21 SOUTH WITH OUT SUN SHADING

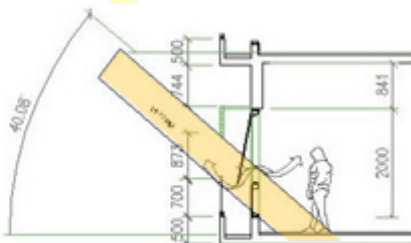

21 SOUTH WEST WITH SUN SHADING

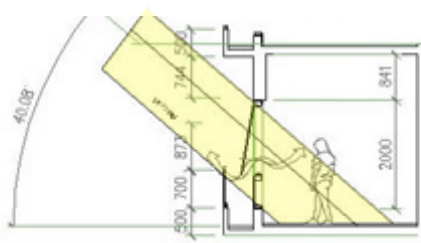

21 SOUTH WEST WITH OUT SUN SHADING

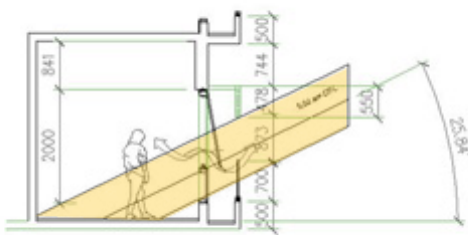

21 NORTH EAST WITH SUN SHADING

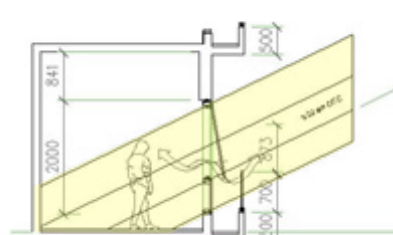

21 NORTH EAST WITHOUT SUN

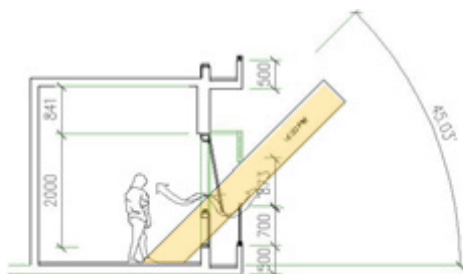

21 NORTH WEST WITH SUN SHADING

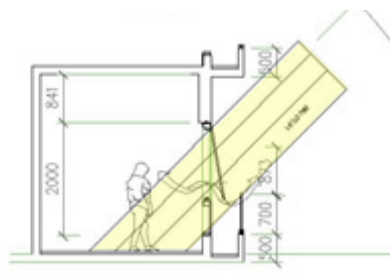

21 NORTH WEST WITH OUT SUN SHADING

The solar protection posed considerably protect the direct solar entrance especially in the façades oriented towards the NE where the sun falls directly in the morning, in the facade NW protecting the sun of the afternoons, SW protecting the Sun entrances from the middle of the day forward and the Sun entrances of the morning where the sun falls horizontally having to use a vertical sun protection.

**Legend**

- With sun shading
- Without sun shading

# 5.3 Radiation



## Legend

Category	Low	Moderate	High	Very High	Extreme
Colour	Green	Yellow	Orange	Red	Purple
Pantone Matching System	375	102	151	032	265
RGB (8 bit values)	40r 149g 0b	247r 228g 0b	248r 89g 0b	216r 0g 29b	107r 73g 200b

↑ Highest value for radiation on the roof is 5580+ Wh

The radiation varies with the orientation, inclination, date and time of study.

According to the solar Atlas the city of Kuala Lumpur has a radiation of 1400 KWH/KWP. In general the hours of sun vary between 5 to 7 hours. The month with lower hours of the sun is the month of December with 4 hours of sun only.

**The sun's path has a vertical tendency, for this reason, heating is more on horizontal surfaces and less on vertical surfaces.**

## 5.3.1 Radiation on the roof

Radiation on the roof is calculated for 21 March at 12:30 pm using the Ecotect software. The survey was made according to the plans and current building design. The natural lighting method with standard CIE overcast covered sky was used to identify the day with the highest cloudiness. The roof is flat therefore its orientation is not important. The radiation value is more than 5580 W/m<sup>2</sup>. Average radiation received throughout the year is of 16800 W/m<sup>2</sup>

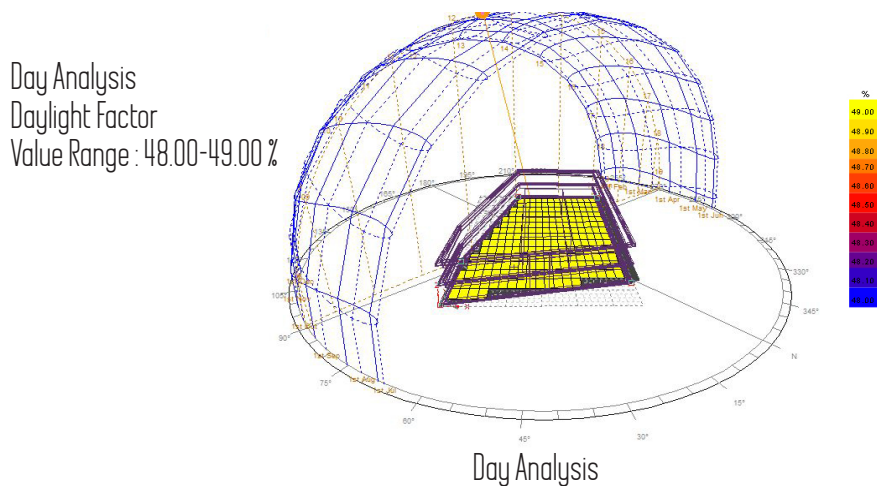

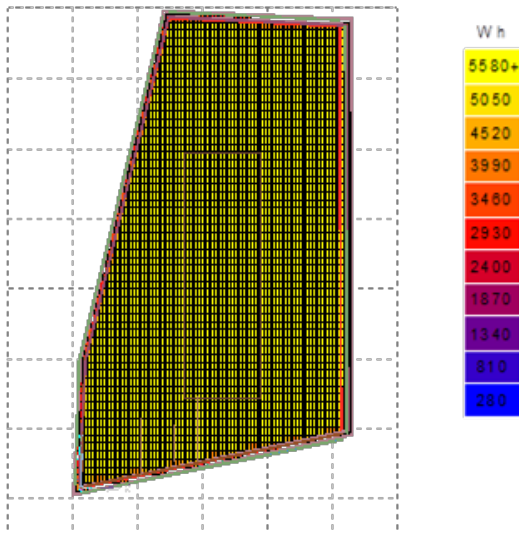

Total Radiation received on the roof on 21th of March = 5580+ wh

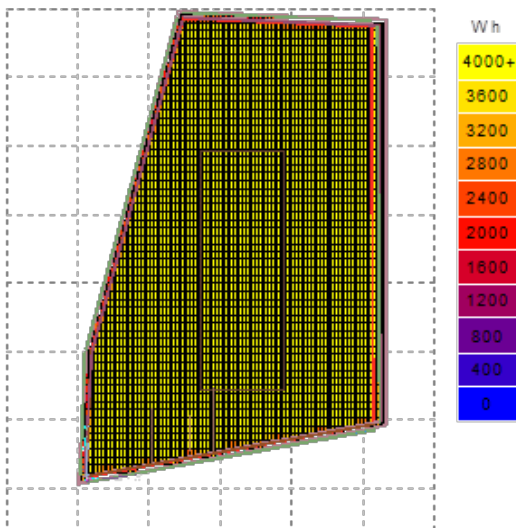

Total Direct Radiation received on the roof on 21th of March= 4000+ wh

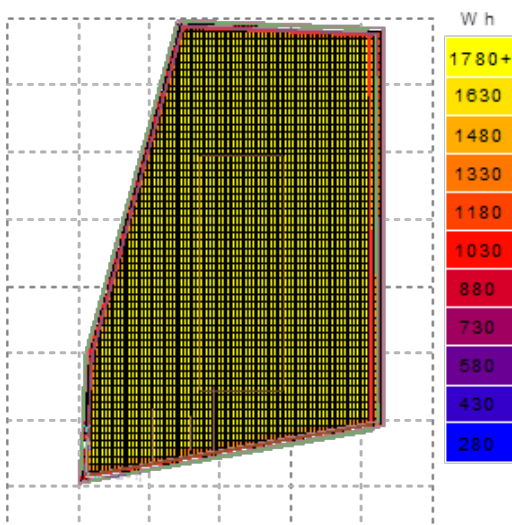

Total Diffused Radiation received on the roof on 21th of March= 1780+ wh

## 5.3.2 Radiation on the walls and interior surfaces

It was considered for the analysis in Ecotect of radiation in the walls with the following information

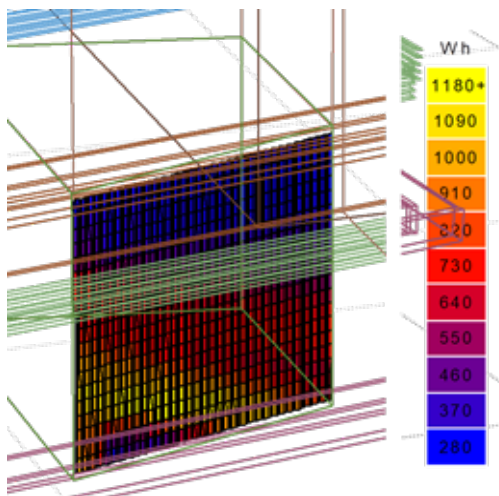

Total Radiation received on the wall on 21th of March is 1180+ wh

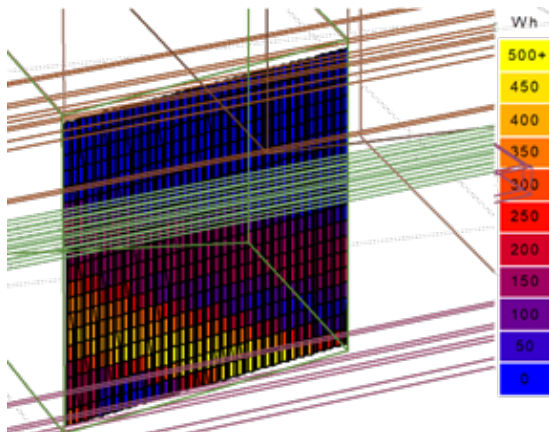

Total Direct Radiation received on the wall on 21th of March is 500+ wh

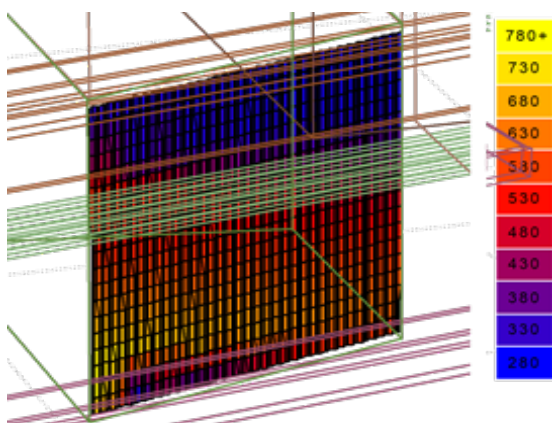

Total Diffused Radiation received on the wall on 21th of March is 780+ wh

On the vertical surfaces the radiation will vary according to the orientation of each one of them. According to the calculation made with the Ecotect Software for the day 21 of March at 10:30am, the horizontal surfaces are heated more than the vertical ones because the sun is almost perpendicular.



# SOUTH WEST

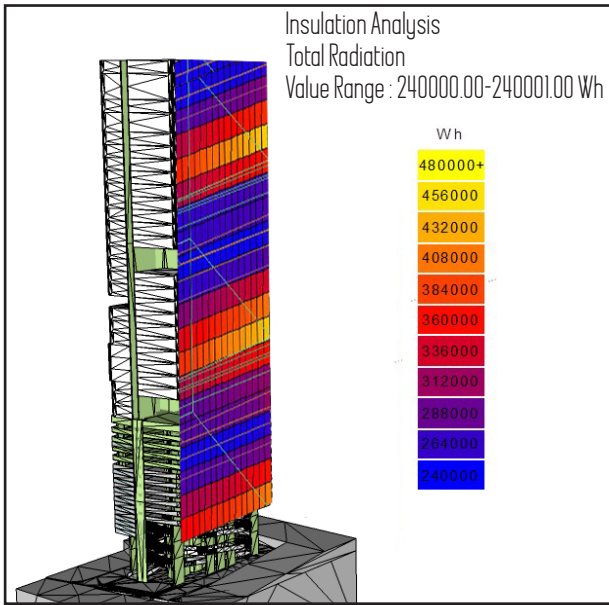

Yearly Cumulative Value

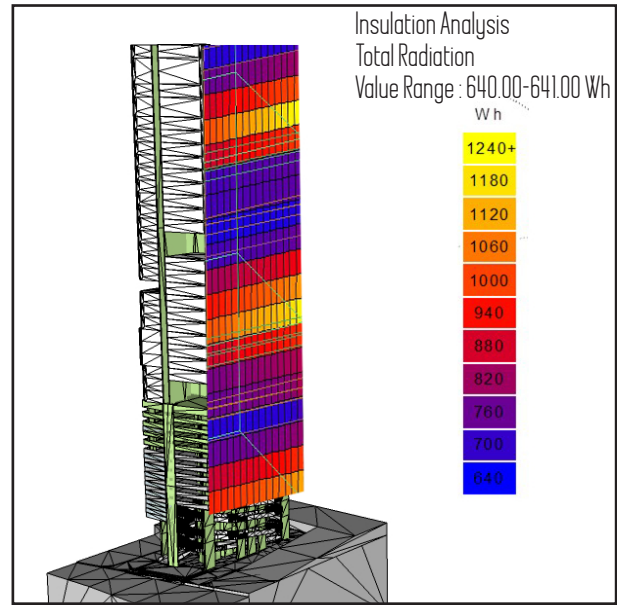

Average Daily Value

# NORTH WEST

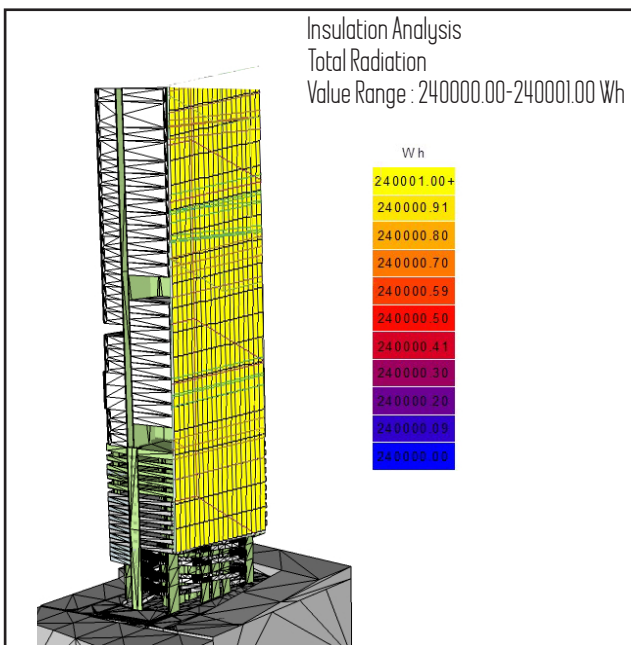

Yearly Cumulative Value

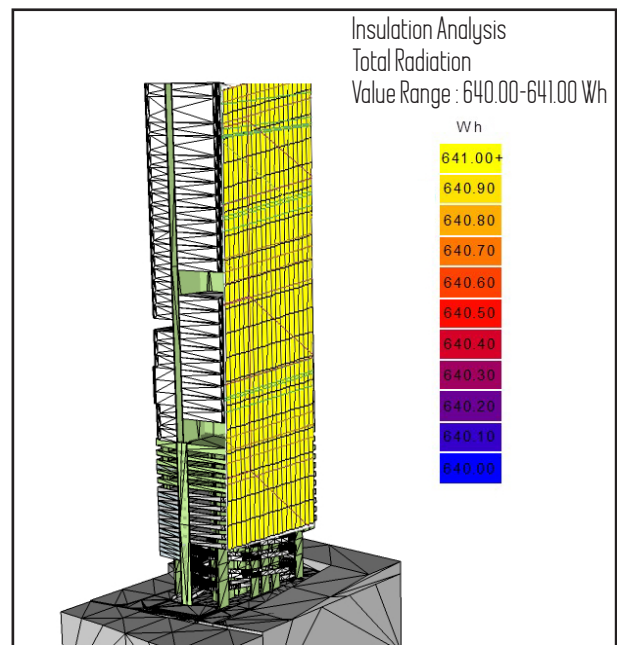

Average Daily Value

# NORTH EAST

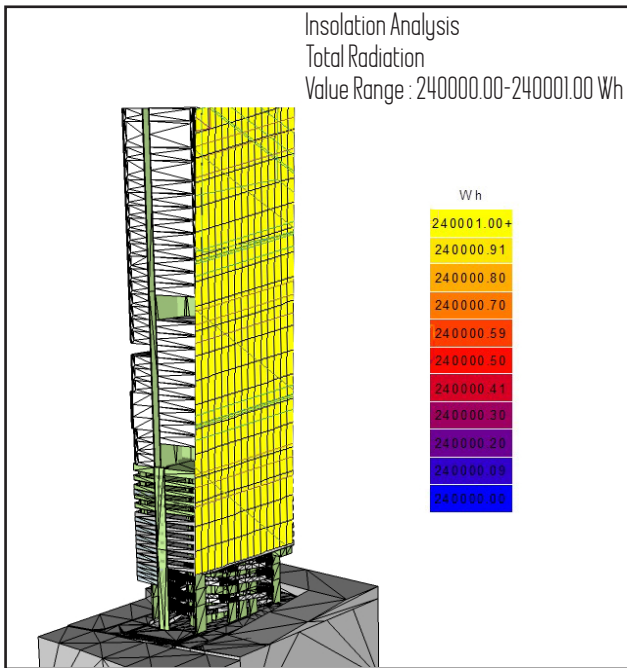

Yearly Cumulative Value

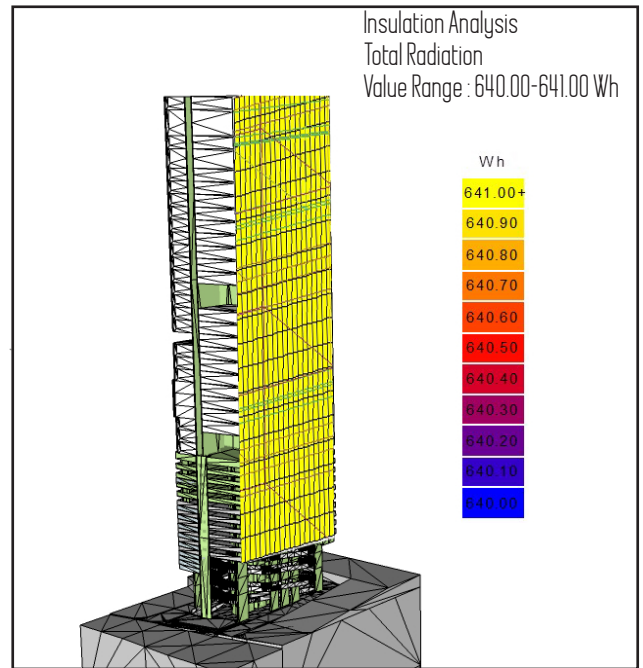

Average Daily Value

# SOUTH

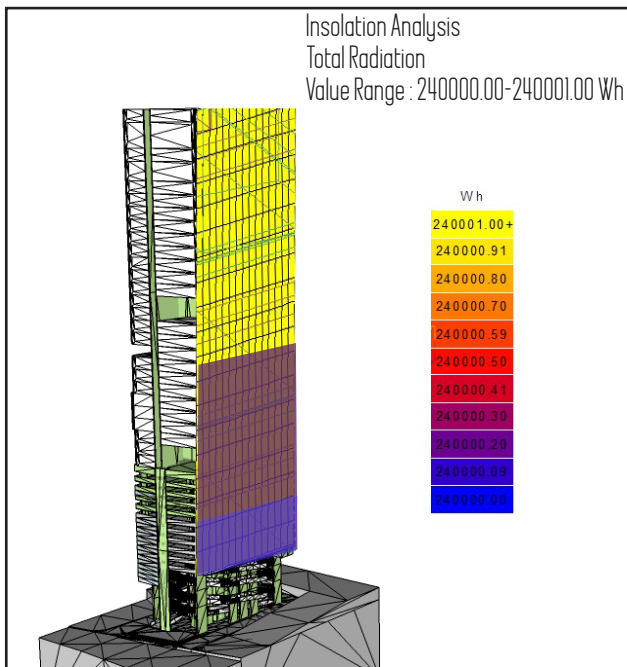

Yearly Cumulative Value

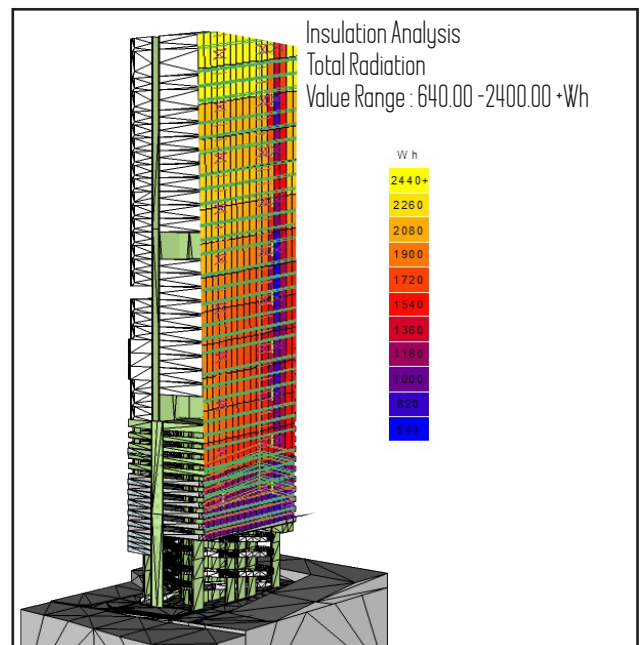

Average Daily Value

## INTERIOR SURFACE

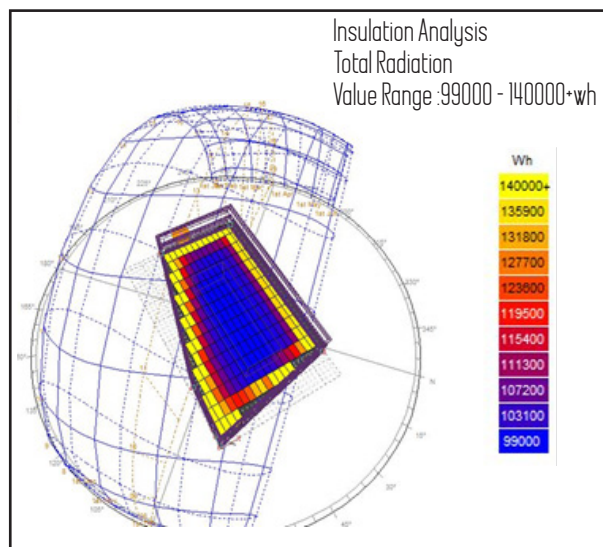

Yearly Cumulative Value

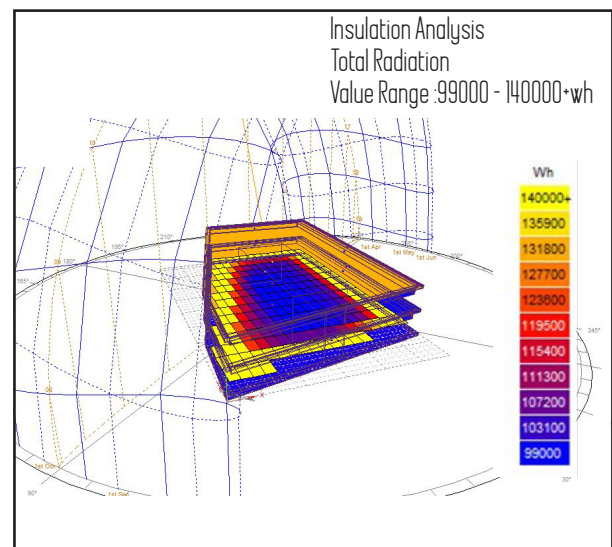

Average Daily Value

## CONCLUSION

It is calculated for March 21 at 12:30 am a radiation measurement using the Ecotect Software, The interior surface was calculated with Ecotect the remainder of the year and found the following results, average of radiation received throughout the year 14000 W/m<sup>2</sup>.

The following values were found: the NE-oriented wall is the one that at the time of measurement receives the highest solar radiation with an equal value of 1318 W/m<sup>2</sup>. It can be noticed that the surfaces closest to the balconies will receive more radiation than the ones inside.

The walls facing the SW receive a total radiation of 1240 w / m<sup>2</sup> ( daily value ) and a yearly cumulative value of 490000 w/h, the walls oriented to NW receive a total radiation of 641 w / m<sup>2</sup> (daily value), and an annual cumulative annual radiation with values of 24000 w/h, the walls oriented to the NE receive a total radiation of 641 w / m<sup>2</sup> daily value, and an annual of 24000 w / m. the ceilings receive a total radiation of 5580 w / m<sup>2</sup>.

According to the calculations, the greatest amount of radiation is given by the facade SW, however the radiation values of the other facades are very high. Direct solar protection is recommended inside the rooms.

## 5.4. Daylight ( without sun shading)

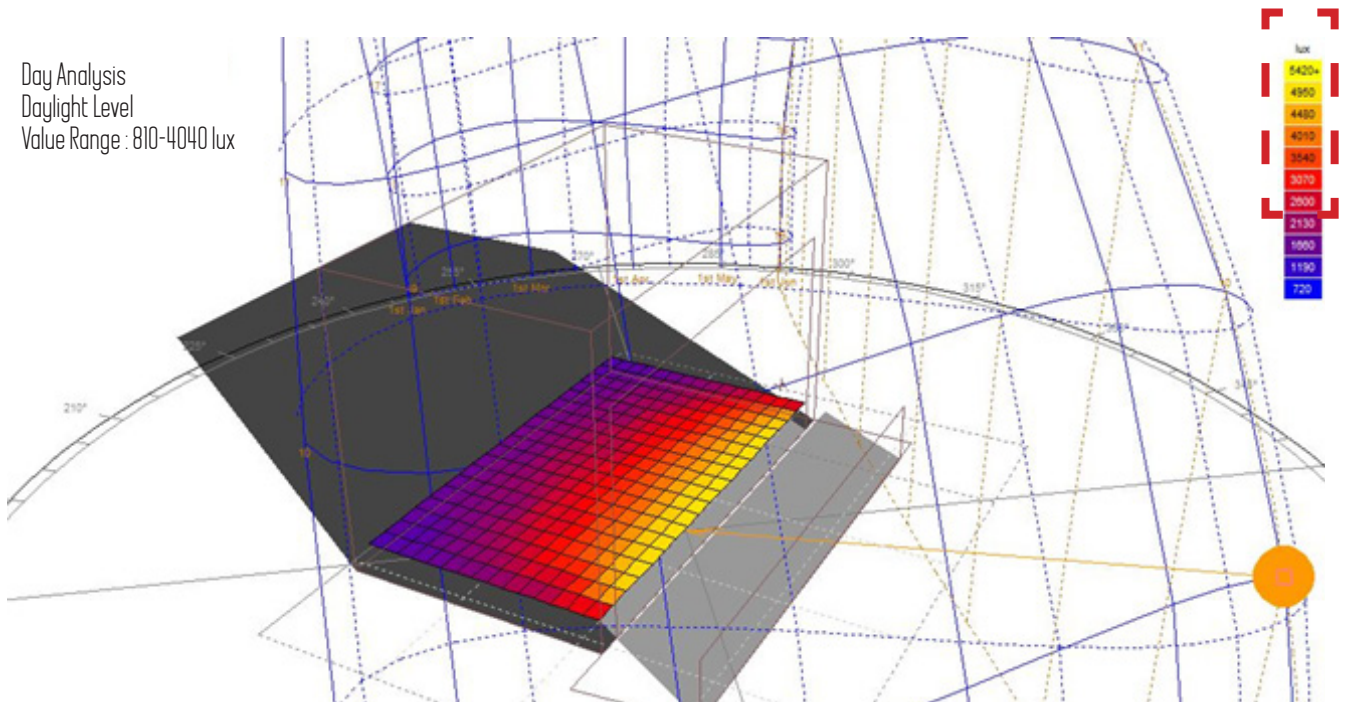

CIE Overcast Sky Daylight Analysis without Sun Shading

The Diagram above shows CIE overcast sky on 21 march at 10:30am shows the light analysis of the room without any sun protection, oriented towards the NE. The area near the window has 5420 lux which is an extremely high value. The intermediate areas where you would find the bed have high values between 4480 lux and 2130 Lux. these areas have direct and uncomfortable solar incidence as there will be glare and the overheating.

DF (%)	LIGHTING	GLARE	THERMAL COMFORT
>6.0	Intolerable	Intolerable	Uncomfortable
3.5-6.0	Tolerable	Uncomfortable	Tolerable
1.0-3.5	Acceptable	Acceptable	Acceptable
<1.0	Perceptible	Imperceptible	Acceptable

Table 1a. Daylight Factors and Impact

## Daylight (sun shading)

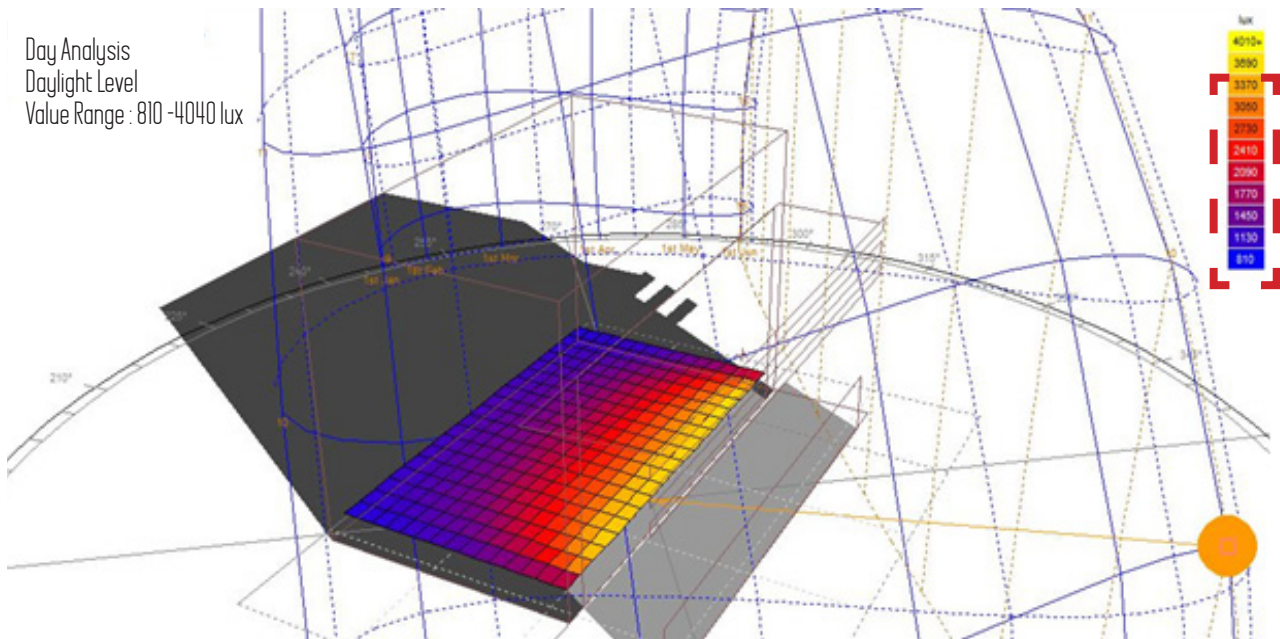

CIE Overcast Sky Daylight Analysis without Sun Shading

The diagram above shows the room with sun protection considerably decreasing excess lux having a range between 3370 Lux to 1770 achieving an equivalent of 2470 lux (a value considerably less than the graph without sun protection).

DF (%)	LIGHTING	GLARE	THERMAL COMFORT
>6.0	Intolerable	Intolerable	Uncomfortable
3.5-6.0	Tolerable	Uncomfortable	Tolerable
1.0-3.5	Acceptable	Acceptable	Acceptable
<1.0	Perceptible	Imperceptible	Acceptable

Table 1a. Daylight Factors and Impact

## Conclusion

According to the table of daylight factors (DF %) the rooms without sun protection will have a direct solar incidence with very high values causing discomfort (higher than 5.4 DF% (orange colored)). The rooms with solar protection sun shading will have acceptable illumination of 1.0 - 3.5 DF %.

# 06 VENTILATION ANALYSIS

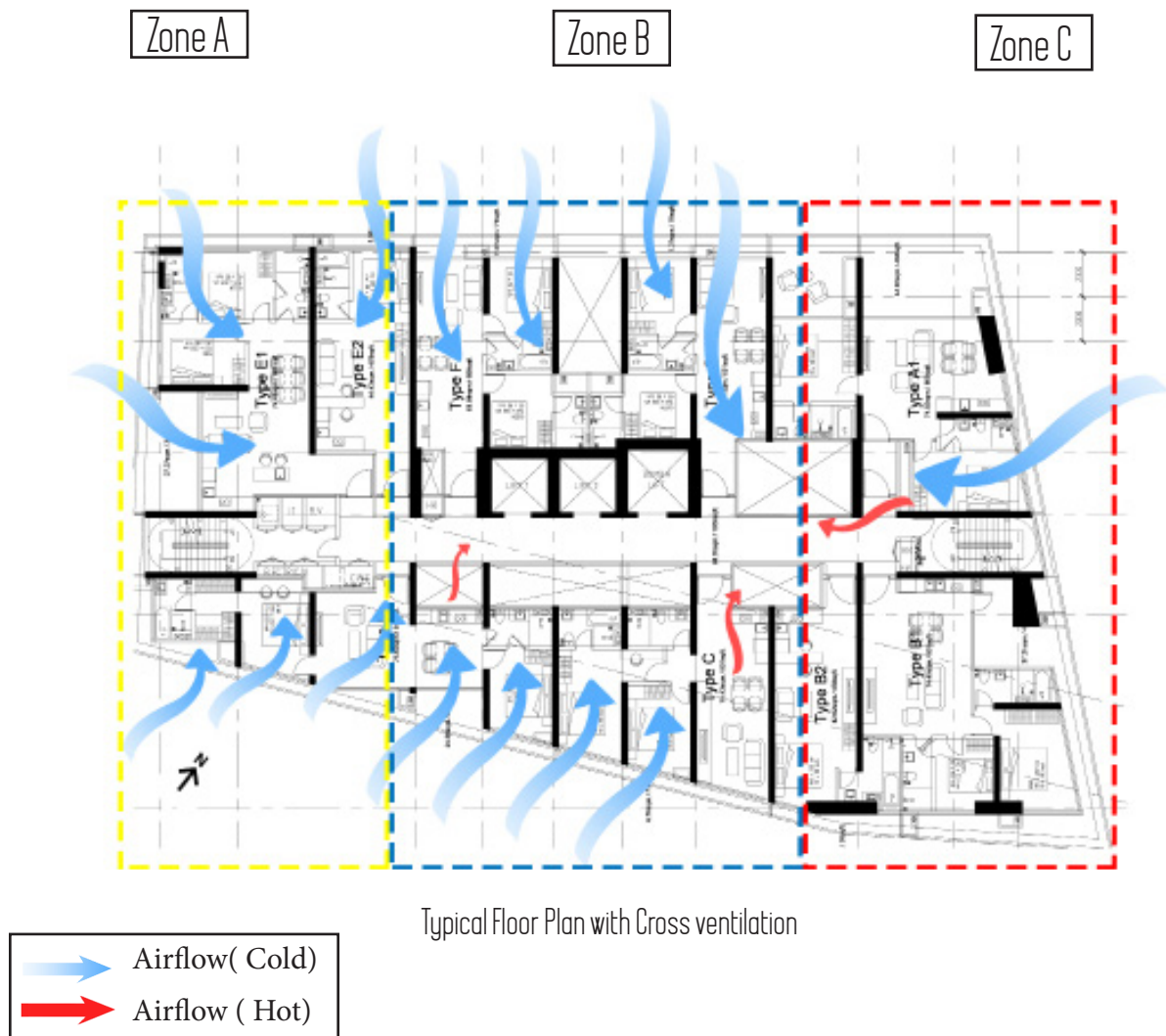

In the Zone B where the central patio where located a corner wind effect will be generate will intensify speed of winds to the interior of the building.

Zones A and C there will be problems of overheating because the wind enters but it won't be able to leave since there are no wind exits.

It is important to have adequate natural ventilation in order to renew the air, reduce temperatures and condensation.

TYPE OF VENTILATION REQUIRED		
CLIMATE	VENTILATION	WIND SPEED (m / s)
WARM - DRY	( a ) y ( c )	0.25 - 2.50
WARM - WET	( a ), ( b ) y ( c )	0.50 - 3.00
MODERATE	( a )	--
COLD CLOUDY	( a )	--
SUNNY	( a )	--

- (a) Ventilation to provide fresh air
- (b) Ventilation to cool the body
- (c) Ventilation to cool the building

Table (6.1)

TYPE OF VENTILATION REQUIRED	
ELEMENT	RANK
Kitchen (commercial)	20 - 40 air changes per hour
Restaurants (with smokers)	10 - 15 air changes per hour
Classrooms	03 - 04 air changes per hour
Offices	02 - 06 air changes per hour
Domestic environments	01 - 01.5 air changes per hour
Busy environments in general	8 litres per second of fresh air per occupant

Table (6.2)

CONVERSIONS OF VENTILATION RANGES	
1 m <sup>3</sup>	1000 litres
1 litre per second (l / s)	3600 litres per hour or 3.6 m <sup>3</sup> per hour

A bedroom of 3.20 m x 3.0 m x 2.5 m (volume 24 m<sup>3</sup>) requires 1 change of air per hour that is to say: 24 m<sup>3</sup> / h

Table (6.3)

According to the table (7.1 Page 43) for hot humid climates it is necessary that, ventilation provides fresh air, cools the body and the building with a speed of 0.50 to 3.00 (m / s).

# 07 Thermal Analysis

## 7.1 Heat Gain and Heat loss of heat

An evaluation is made of the thermal balance of the room oriented to the NE according to the material used. The heat gain (hottest time ) and heat loss (coldest time) is calculated heat according to the location conditions, materials and openings.

CONDITIONS OF CALCULATION :		
Location :		
Height (M.A.S.L.) and Temperatures ( °C) ( In the hottest and the coldest month)		
Station / Height	0 msn	
Max. Temperature	32.8	
Min. Temperature	23	9.8
Max. Temperature	31.2	
Min. Temperature	21.7	-9.5

Windows (2 options)		
Dimension ( l x h )		
Window 1 (NE)	2.00 x 4.63 = 9m <sup>2</sup>	Summer shadow / Winter Sun
Simple 6 mm		
Window 2 (SE)	3.00 x 2.00 = 6m <sup>2</sup>	Summer sun / Winter shade
Features		
	simple 6 mm	

Table (7.1)

Perimeter Edge: Non-insulated (4.60)/with or without insulation
Infiltration Factor: Normal
Inhabited by: 2 people
Summer ventilation: ADR 1.00 < 1.800 M.A.S.L. = 15 C.A./H/HA 0339



-Materials to be used and their values

Table (7.2 Page 44) Materials, areas and values of total resistance total (R total) and global coefficient of thermal transmission (U)

Properties	Brick wall	Concrete of roof	Window 1 (NE)	Concrete Lintel	Window2
R total (m <sup>2</sup> x °K/W)	1.23	0.33	0.21	0.33	0.16
U (W/m <sup>2</sup> x K)	0.81	3.03	4.76	3.51	5.9
Área (m <sup>2</sup> )	72.17	4.6	9	3.03	6

Table (7.2)

## Manually Analysis

Conclusion

Profit and loss

Hottest period	3956.2 W/h	The housing is not within the comfort limits (+-500 W / h) having gains of 2196.65 W / h
Warm Period	1760.20 W/h	

Table (7.3)Legend

Heat gain and heat loss were calculated and the following results were obtained:

- The gain in the hottest month was 3956.2 W/h (notably high).The reason being is the type of specified glass to prevent heat high heat gain it is necessary to protect the glass from radiation (UV and infrared rays).
- The heat loss in it the coldest month was 1760.20 W/h
- The rooms are not within the limits of comfort (+ 500 W/h) having a heat gain of 2196.65 W/h.

# Ecotect Software Analysis

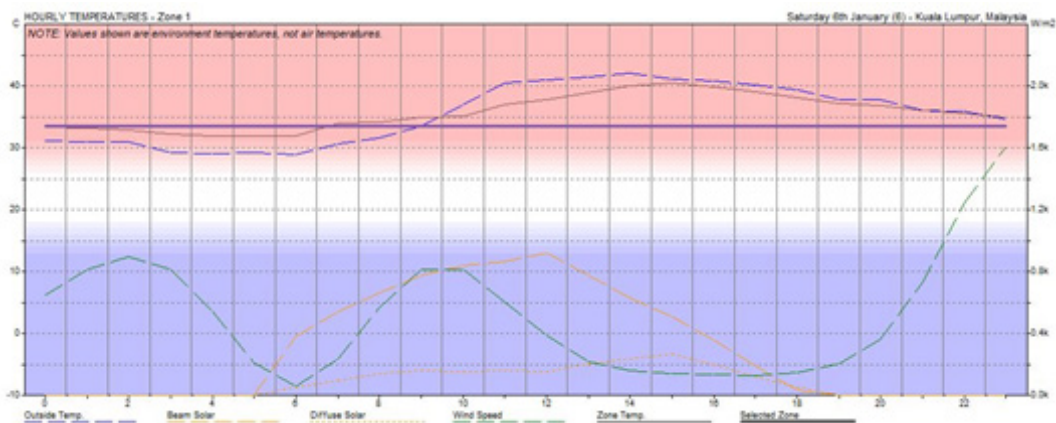

Table 7.4

In the graph we have taken into account the thermal balance of the hottest day and it is noticed that the Purple Line is outside the comfort zone. In both manual analysis and through the Ecotect software The room environment is not within the thermal comfort.

## 7.2 Evaluation of the temperature depending on the thermal behavior of the material used

Two measurements of the temperature in the building were made at 9:00 a.m. using the Ecotect Software in the month of March and September. The Ecotect was used to measure the internal and external temperature without sun shading, we considered a human being with 1 clothes of thermal insulation, the internal humidity in 80%, the internal air speed 0.50 m/sec, the occupants were considered with a sedentary activity with a value of 70 w, 1.00 changes per hour a sensible gain of 5 and latent of 2.

For the calculation, the highest average temperature stage was taken into account.

The internal radiant temperature has been calculated considering the materials described above in the thermal balance and the results shown in (Table 7.4 Page 45 ) were obtained:

The outdoor temperature from 9 a.m. is above the comfort zone with 30.5 degrees. The difference between the highest value and the lowest outside temperature is almost 11.7 degrees which is considered unstable. The interior radiant temperature is more stable, the difference is 6.2 degrees.

The outdoor temperature has its highest value at 16:00 pm with 34.2 degrees and its value under 24 degrees in the early morning hours.

The interior radiant temperature has its highest value at 16:00 pm with 34.2 degrees and its value less than 28.7 degrees, achieving a difference of 6.6 degrees. The greatest difference in temperature between indoor and outdoor radiant temperatures would be in the evening hours at 22:00 pm with 3.9 degrees.

The internal radiant temperature is above comfort throughout the day, as well as the external radiant temperature. It is important to analyse these to generate an internal comfort protecting the solar entry directly into the rooms and to reduce the amount of glass on the façades to avoid not to overheat the interior spaces. The external temperature at its most critical stage (16:00 h) is out of comfort with a temperature of 34.2 °.

HOURS	INTERNAL RADIANT TEMPERATURE INSIDE (C)	OUTDOOR RADIANT TEMPERATURE OUTSIDE ( C )	NO SHADING SINGLE GLAZING TEMP.DIF (C)
6	28.7	24.1	4.6
7	28.7	24.2	4.5
8	29.6	26.3	3.3
9	30.5	28.3	2.2
10	31.1	30.4	0.7
11	31.9	31.2	0.7
12	33	32	1
13	33.6	32.8	0.8
14	34.2	33.8	0.4
15	34.2	34.8	-0.6
16	34.2	35.8	-1.6
17	33.8	33.7	0.1
18	33	31.6	1.4
19	32.3	29.5	2.8
20	31.4	28.4	3
21	30.6	27.2	3.4
22	30	26.1	3.9
23	29.8	25.9	3.9

Different between Internal and External Radiant

# 08 Proposals and Recommendations

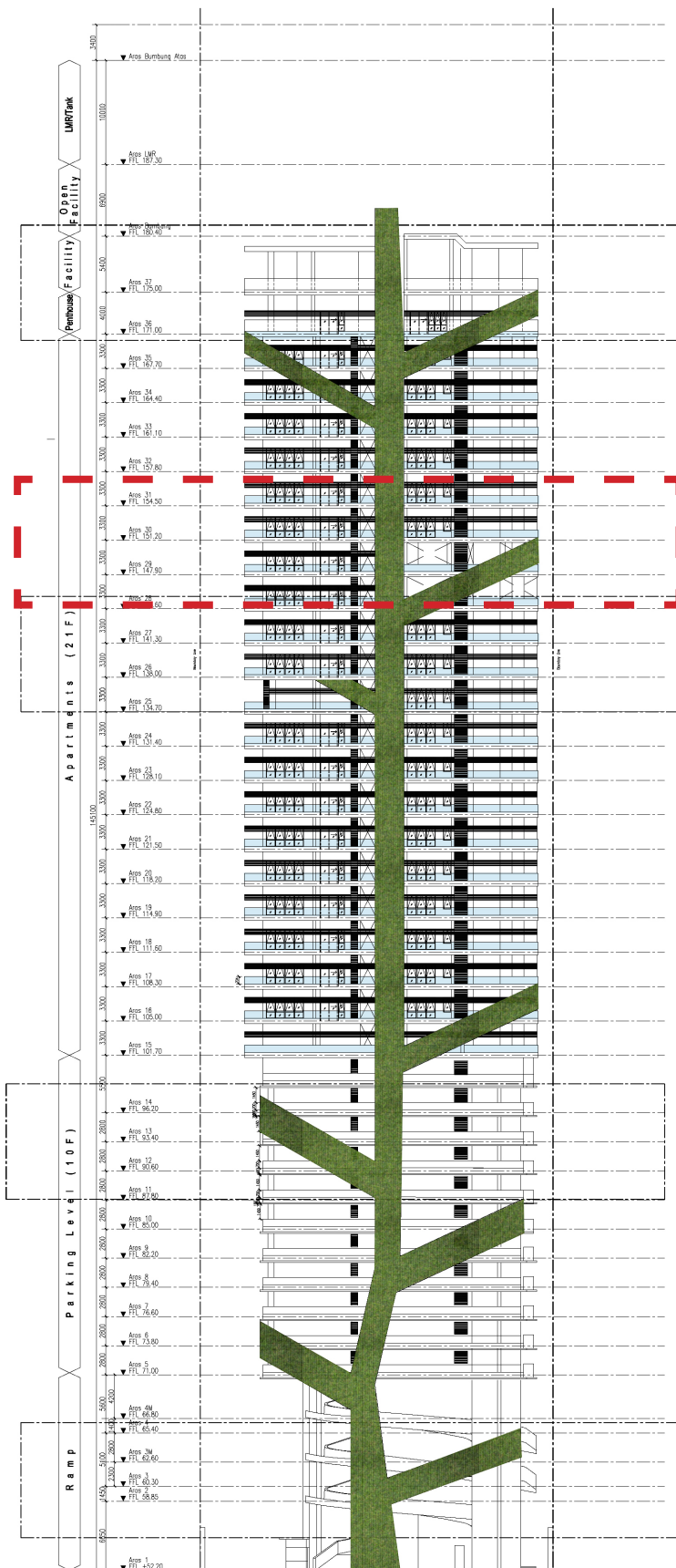

The vertical solar protection of the NE, NW, SW and S façades is proposed

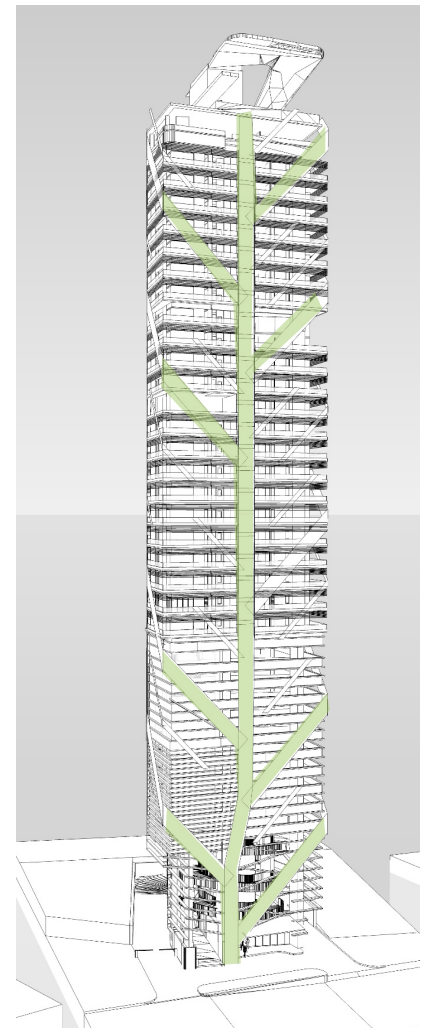

# Plan and section of sun shading ( 55 cm) - Option 1

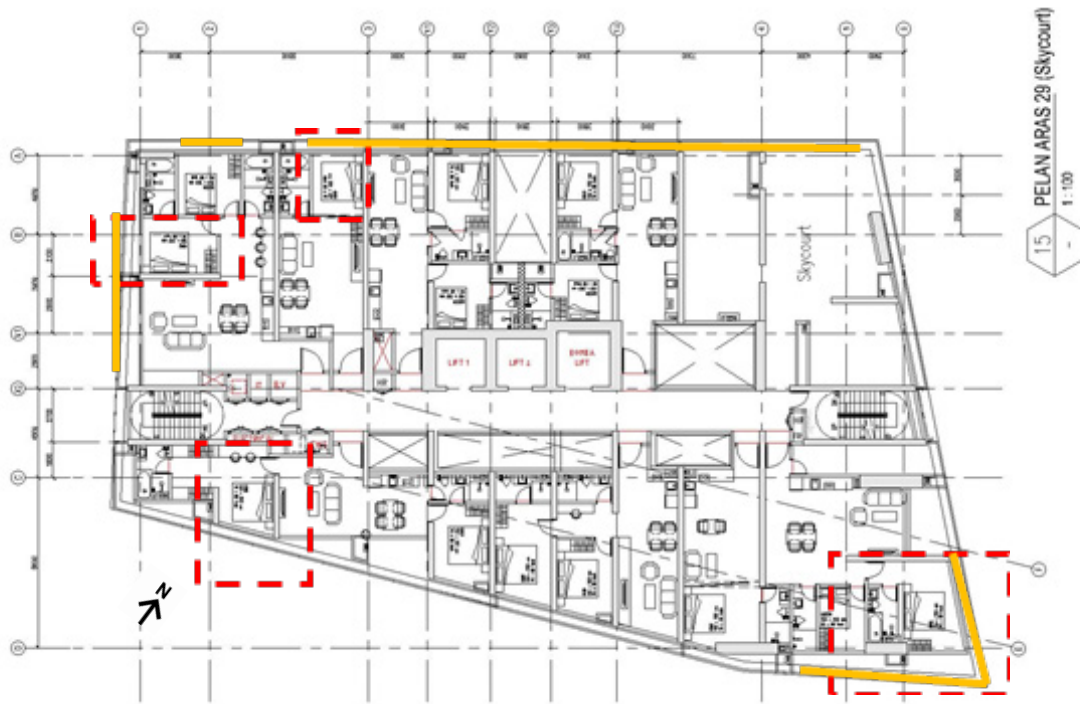

Typical Floor : The environment to be analysed will be the main room of each elevation.

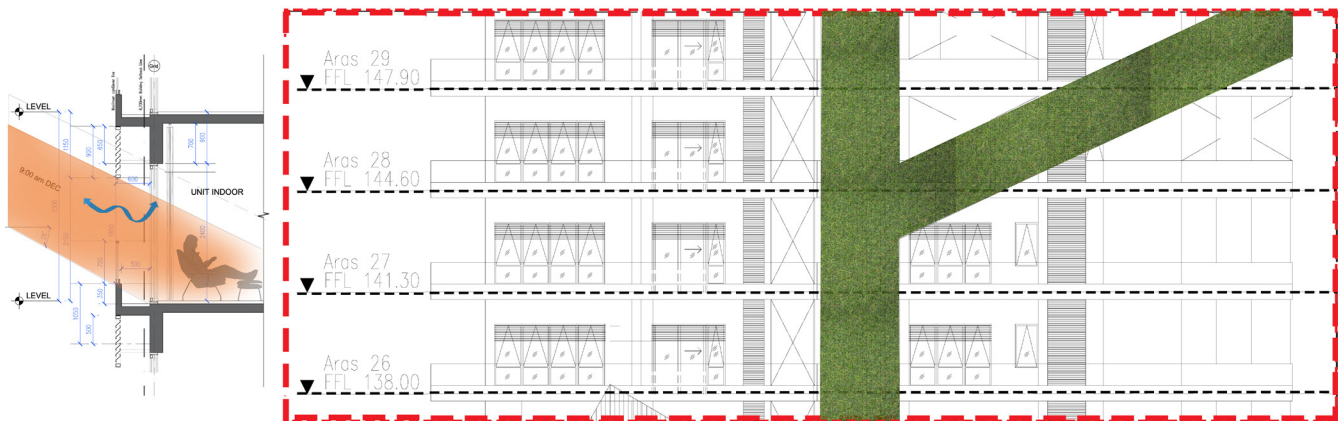
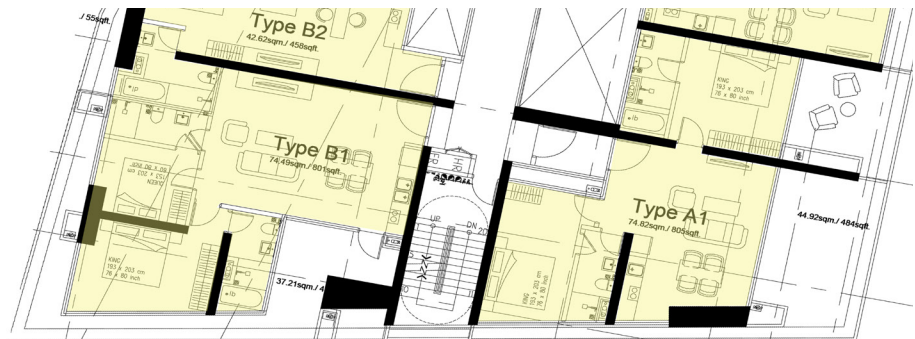

Typical section and Floor plan.

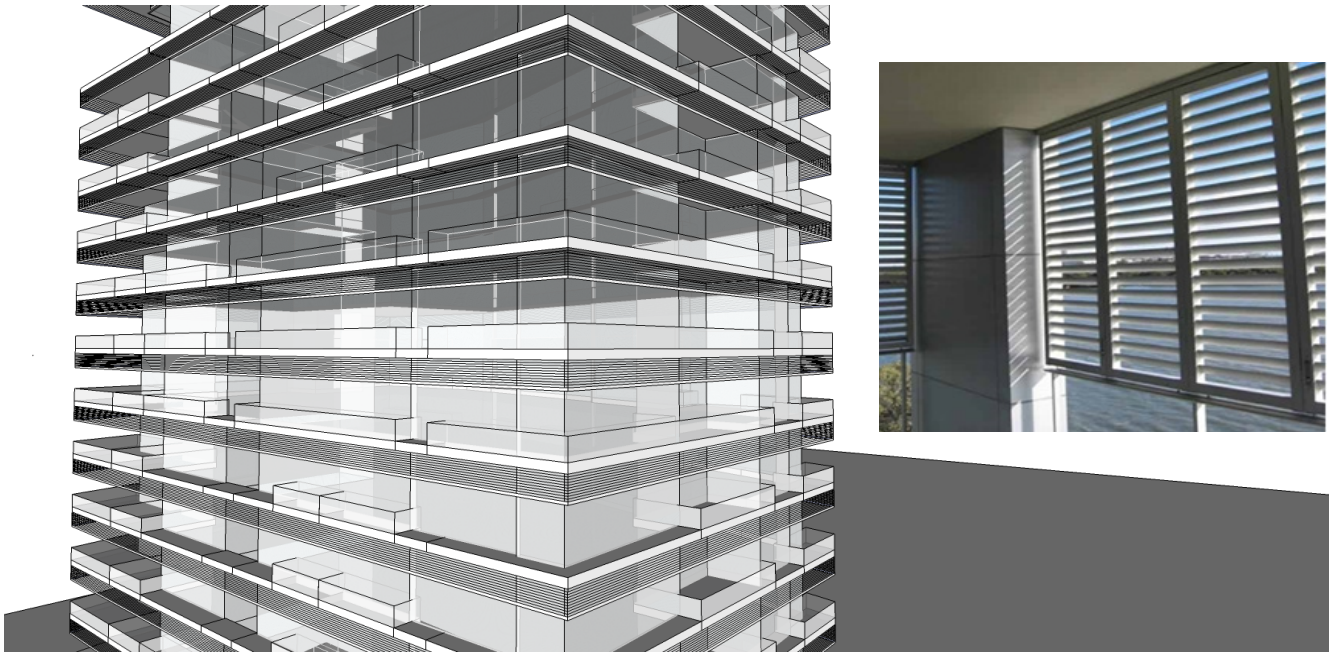

Reference of the sunshading

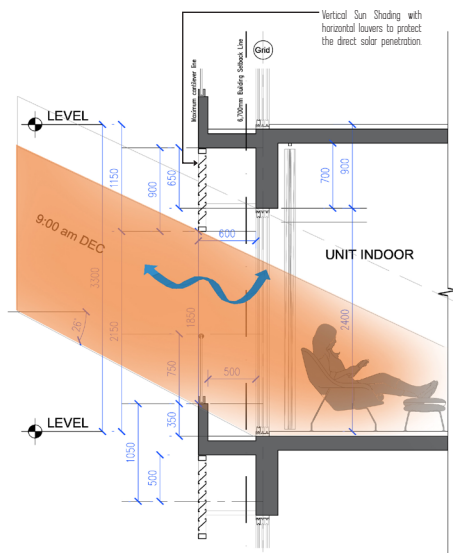

21 NE Sun Shading at 9.00am

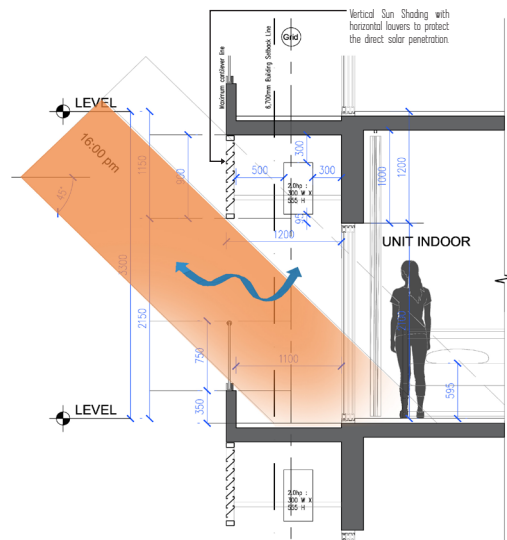

21 NW Sun Shading at 16.00pm

# 09 Bibliography

CZAJKOWSKI, Jorge D y GÓMEZ, Analía F.

Introduction to the bioclimatic design and the energetic energy economy.

EVANS, Martin; Housing, Climate and Comfort. The Architectural Press. London, 1980.

GIVONI, Baruch; Climate Considerations in Building and Urban Design. Van Nostrand Reinhold. New York, 1998.

GONZALO, Guillermo E.; Manual de Arquitectura Bioclimática. Tucumán, 1998.

LACOMBA, Ruth (Compiladora) y otros, Manual de Arquitectura Solar. Edit. Trillas. México, 1991.

OLGYAY, Victor; Architecture and Climate Bioclimatic design manual for architects and urban planners. Edit. Gustavo Gili. Barcelona, 1998. (en inglés)

SERRA, Rafael; Architecture and Climates. Edit. Gustavo Gili. Barcelona, 1999.

VÉLEZ, Roberto, Ecology in Architectural Design. Edit. Trillas, México, 1991

WIESER, Martín; Solar geometry for architects. Lima, 2006.

## ELECTRONIC ADDRESSES

ARQUINSTAL [Consulta: 13-03-2012]

<http://www.arquinstal.com.ar/>

SENAMHI [Consulta: 13-03-2012]

<http://www.senamhi.gob.pe/>

CAAMAÑO MARTÍN, Estefanía, y otros, "Viviendas solares autosuficientes: participación de la Universidad Politécnica de Madrid en el Concurso "solar Decathlon", [Consulta: 13-03-2012]

<http://informesdelaconstruccion.revistas.csic.es/index.php/informesdelaconstruccion/article/view/447/520>

CHÁVEZ DEL VALLE, Francisco Javier, Zona variable de confort térmico, [Consulta: 13-03-2012]

<http://www.tesisenred.net/handle/10803/6104;jsessionid=6EADCA884B2F5EB08BB780B53505CAE2.tdx2>

GIANO CANALES, Alexander, Qué es la Arquitectura Bioclimática, [Consulta: 13-03-2012]

[http://www.habitarnatural.com/artls/arquitectura\\_bioclimatica.pdf](http://www.habitarnatural.com/artls/arquitectura_bioclimatica.pdf)

INSTITUTO DE ARQUITECTURA TROPICAL DE COSTA RICA. [Consulta: 13-03-2012]

<http://www.arquitecturatropical.org>

MARSH, Andrew; "Natural Frequency".

<http://naturalfrequency.com> [Consulta: 13-03-2012]

